

# *Grizzly* *Industrial, Inc.*®

## MODEL G0636X 17" ULTIMATE BANDSAW OWNER'S MANUAL



COPYRIGHT © MAY, 2007 BY GRIZZLY INDUSTRIAL, INC.  
**WARNING: NO PORTION OF THIS MANUAL MAY BE REPRODUCED IN ANY SHAPE  
OR FORM WITHOUT THE WRITTEN APPROVAL OF GRIZZLY INDUSTRIAL, INC.**  
#BL9291 PRINTED IN TAIWAN



## **WARNING!**

**This manual provides critical safety instructions on the proper setup, operation, maintenance and service of this machine/equipment.**

**Failure to read, understand and follow the instructions given in this manual may result in serious personal injury, including amputation, electrocution or death.**

**The owner of this machine/equipment is solely responsible for its safe use. This responsibility includes but is not limited to proper installation in a safe environment, personnel training and usage authorization, proper inspection and maintenance, manual availability and comprehension, application of safety devices, blade/cutter integrity, and the usage of personal protective equipment.**

**The manufacturer will not be held liable for injury or property damage from negligence, improper training, machine modifications or misuse.**



## **WARNING!**

**Some dust created by power sanding, sawing, grinding, drilling, and other construction activities contains chemicals known to the State of California to cause cancer, birth defects or other reproductive harm. Some examples of these chemicals are:**

- **Lead from lead-based paints.**
- **Crystalline silica from bricks, cement and other masonry products.**
- **Arsenic and chromium from chemically-treated lumber.**

**Your risk from these exposures varies, depending on how often you do this type of work. To reduce your exposure to these chemicals: Work in a well ventilated area, and work with approved safety equipment, such as those dust masks that are specially designed to filter out microscopic particles.**

# Table of Contents

<b>INTRODUCTION .....</b>	<b>2</b>	<b>SECTION 4: OPERATIONS .....</b>	<b>28</b>
Foreword.....	2	Operation Safety .....	28
Contact Info .....	2	Overview .....	28
Machine Data Sheet .....	3	Foot Brake .....	29
Identification.....	5	Guide Post.....	29
<b>SECTION 1: SAFETY .....</b>	<b>6</b>	Fine Tune Tracking.....	30
Safety Instructions for Machinery .....	6	Blade Lead.....	30
Additional Safety Instructions for Bandsaws ..	8	Table Tilt .....	31
<b>SECTION 2: CIRCUIT REQUIREMENTS .....</b>	<b>9</b>	Ripping.....	32
220V Single-Phase .....	9	Crosscutting .....	32
<b>SECTION 3: SETUP .....</b>	<b>10</b>	Resawing .....	33
Setup Safety .....	10	Cutting Curves .....	33
Items Needed for Setup.....	10	Stacked Cuts .....	34
Unpacking .....	10	Blade Information.....	34
Inventory .....	11	Blade Changes .....	36
Hardware Recognition Chart .....	12	<b>SECTION 5: ACCESSORIES.....</b>	<b>37</b>
Clean Up.....	13	<b>SECTION 6: MAINTENANCE.....</b>	<b>39</b>
Site Considerations.....	13	Schedule .....	39
Moving & Placing Base Unit .....	14	Cleaning.....	39
Mounting to Shop Floor .....	15	Unpainted Cast Iron.....	39
Guide Post Handwheel.....	15	Brushes.....	39
Blade Tracking.....	16	Lubrication .....	39
Positive Stop.....	17	<b>SECTION 7: SERVICE .....</b>	<b>42</b>
Dust Collection.....	18	Troubleshooting .....	42
Fence .....	19	Checking and Tensioning V-Belts .....	44
Test Run .....	20	Replacing V-Belts .....	45
Tensioning Blade .....	21	Adjusting Tension Lever .....	45
Adjusting Blade Guide Bearings.....	21	Adjusting Wheel and Blade Brushes .....	46
Adjusting Support Bearings .....	23	Wheel Alignment.....	46
Aligning Table .....	25	Electrical Components.....	49
Aligning Fence .....	26	Wiring Diagram .....	50
Pointer Calibration .....	27	Main Parts Breakdown.....	51
Miter Gauge .....	27	Fence/Guides Parts Breakdown.....	52
		Labels/Cosmetic Parts.....	56
		<b>WARRANTY AND RETURNS .....</b>	<b>57</b>

# INTRODUCTION

---

---

## Foreword

---

---

We are proud to offer the Model G0636X 17" Ultimate Bandsaw. This machine is part of a growing Grizzly family of fine woodworking machinery. When used according to the guidelines set forth in this manual, you can expect years of trouble-free, enjoyable operation and proof of Grizzly's commitment to customer satisfaction.

The specifications, drawings, and photographs illustrated in this manual represent the Model G0636X when the manual was prepared. However, owing to Grizzly's policy of continuous improvement, changes may be made at any time with no obligation on the part of Grizzly.

For your convenience, we always keep current Grizzly manuals available on our website at **www.grizzly.com**. Any updates to your machine will be reflected in these manuals as soon as they are complete. Visit our site often to check for the latest updates to this manual!

## Contact Info

---

---

If you have any comments regarding this manual, please write to us at the address below:

Grizzly Industrial, Inc.  
c/o Technical Documentation Manager  
P.O. Box 2069  
Bellingham, WA 98227-2069  
Email: manuals@grizzly.com

We stand behind our machines. If you have any service questions or parts requests, please call or write us at the location listed below.

Grizzly Industrial, Inc.  
1203 Lycoming Mall Circle  
Muncy, PA 17756  
Phone: (570) 546-9663  
Fax: (800) 438-5901  
E-Mail: techsupport@grizzly.com  
Web Site: <http://www.grizzly.com>







# MACHINE DATA SHEET

Customer Service #: (570) 546-9663 • To Order Call: (800) 523-4777 • Fax #: (800) 438-5901

## MODEL G0636X 17" ULTIMATE BANDSAW

### Product Dimensions:

Weight ..... 620 lbs.  
 Length/Width/Height ..... 35¼" x 33¾" x 78½"  
 Foot Print (Length/Width) ..... 29½" x 23½"

### Shipping Dimensions:

Type ..... Wood Slat Crate  
 Content ..... Machine  
 Weight ..... 675 lbs.  
 Length/Width/Height ..... 36½" x 27½" x 88"

### Electrical:

Switch ..... Magnetic w/Thermal Overload Protection  
 Switch Voltage ..... 220V  
 Recommended Circuit Size ..... 30 amp  
 Recommended Plug Type ..... L6-30  
 Plug Included ..... No

### Motor:

Type ..... TEFC Capacitor Start Induction  
 Horsepower ..... 5 HP  
 Voltage ..... 220V  
 Phase ..... Single  
 Amps ..... 22A  
 Speed ..... 1725 RPM  
 Cycle ..... 60 Hz  
 Number Of Speeds ..... 1  
 Power Transfer ..... Belt Drive  
 Bearings ..... Shielded and Permanently Lubricated

### Main Specifications:

#### Operation Information

Blade Speed ..... 4500 FPM  
 Table Tilt ..... Left 5°, Right 45°

#### Cutting Capacities

Maximum Cutting Height ..... 16"  
 Throat Capacity Left of Blade ..... 16½"

#### Blade Information

Standard Blade Length ..... 160"-162"  
 Blade Width Range ..... ⅛"-1⅜"  
 Blade Guides ..... Ball Bearing



**Table Information**

Table Length .....	21"
Table Width .....	25½"
Table Thickness .....	2"
Floor to Table Height.....	35½"

**Fence Information**

Locks in Front.....	Yes
Locks in Rear .....	No
Adjustable for Blade Lead .....	Yes
Resaw Fence Plate Height.....	6"

**Dust Collection**

Number of Dust Ports.....	2
Size of Dust Ports .....	4"
Required CFM at Each Dust Port .....	400 CFM

**Construction Materials**

Table.....	Precision Ground Cast Iron
Rip Fence .....	Cast Iron
Resaw Fence .....	Deluxe Extruded Aluminum
Wheels.....	Computer Balanced Cast Iron
Tire Material .....	Rubber
Wheel Cover.....	Pre-Formed Steel
Body .....	One Piece Reinforced Steel
Paint .....	Powder Coated

**Other Specifications:**

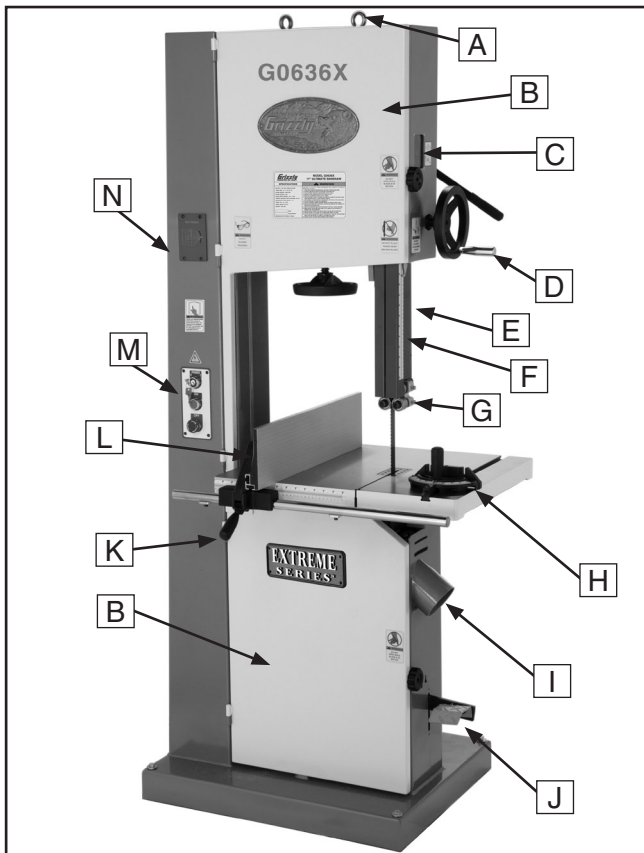
Country Of Origin .....	Taiwan
Warranty.....	1 Year
Serial Number Location .....	ID Label on Upper Wheel Cover
Assembly & Setup Time .....	1 Hour

**Features:**

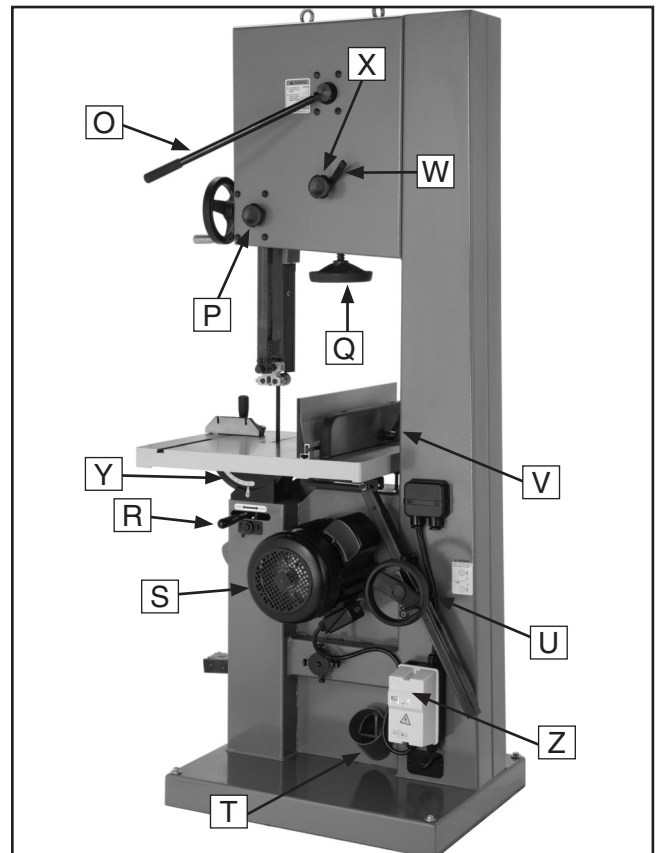
- Ball Bearing Blade Guides
- Quick Change Blade Release/Tensioner
- Micro-Adjusting Rack & Pinion Table Tilt
- Rack & Pinion Upper Blade Guide Height Adjustment
- Computer Balanced Cast Iron Wheels with Grizzly Bear Head Cut-Outs
- Blade Tension Indicator
- Magnifying Window over Fence Scale
- Height Scale for Upper Blade Guides
- Blade Tracking Window
- Hinged Wheel Covers with Safety Lock
- Deluxe Cast Iron Fence with Extruded Aluminum Resaw Fence Attachment
- Foot Brake Stop
- Included Miter Gauge
- Included 1" Blade
- Two 4" Dust Ports



# Identification



**Figure 1.** G0636X front view.



**Figure 2.** G0636X rear view.

- A. Eye Bolt
- B. Hinged Wheel Covers
- C. Blade Tracking Window
- D. Guide Post Handwheel
- E. Cutting Height Scale
- F. Guide Post
- G. Ball Bearing Blade Guides
- H. Miter Gauge
- I. 4" Dust Port
- J. Foot Brake
- K. Fence Lock Lever
- L. Resaw Fence
- M. Key Switch, Start & Stop Buttons
- N. Blade Tension Scale

- O. Quick Release Blade Tension Lever
- P. Guide Post Lock Knob
- Q. Blade Tension Handwheel
- R. Table Tilt Lock Lever
- S. Motor
- T. 4" Dust Port
- U. Table Tilt Handwheel
- V. Rip Fence
- W. Blade Tracking Lock Lever
- X. Blade Tracking Knob
- Y. Table Tilt Scale
- Z. Magnetic Switch



# SECTION 1: SAFETY

## WARNING

### For Your Own Safety, Read Instruction Manual Before Operating this Machine

The purpose of safety symbols is to attract your attention to possible hazardous conditions. This manual uses a series of symbols and signal words intended to convey the level of importance of the safety messages. The progression of symbols is described below. Remember that safety messages by themselves do not eliminate danger and are not a substitute for proper accident prevention measures.



Indicates an imminently hazardous situation which, if not avoided, **WILL** result in death or serious injury.



Indicates a potentially hazardous situation which, if not avoided, **COULD** result in death or serious injury.



Indicates a potentially hazardous situation which, if not avoided, **MAY** result in minor or moderate injury. It may also be used to alert against unsafe practices.

**NOTICE**

This symbol is used to alert the user to useful information about proper operation of the machine.

## WARNING

### Safety Instructions for Machinery

- 1. READ THE ENTIRE MANUAL BEFORE STARTING MACHINERY.** Machinery presents serious injury hazards to untrained users.
- 2. ALWAYS USE ANSI APPROVED SAFETY GLASSES WHEN OPERATING MACHINERY.** Everyday eyeglasses only have impact resistant lenses—they are NOT safety glasses.
- 3. ALWAYS WEAR A NIOSH APPROVED RESPIRATOR WHEN OPERATING MACHINERY THAT PRODUCES DUST.** Wood dust can cause severe respiratory illnesses.
- 4. ALWAYS USE HEARING PROTECTION WHEN OPERATING MACHINERY.** Machinery noise can cause permanent hearing loss.
- 5. WEAR PROPER APPAREL. DO NOT** wear loose clothing, gloves, neckties, rings, or jewelry that can catch in moving parts. Wear protective hair covering to contain long hair and wear non-slip footwear.
- 6. NEVER OPERATE MACHINERY WHEN TIRED OR UNDER THE INFLUENCE OF DRUGS OR ALCOHOL.** Be mentally alert at all times when running machinery.



# WARNING

## Safety Instructions for Machinery

7. **ONLY ALLOW TRAINED AND PROPERLY SUPERVISED PERSONNEL TO OPERATE MACHINERY.** Make sure operation instructions are safe and clearly understood.
8. **KEEP CHILDREN AND VISITORS AWAY.** Keep all children and visitors a safe distance from the work area.
9. **MAKE WORKSHOP CHILDPROOF.** Use padlocks, master switches, and remove start switch keys.
10. **NEVER LEAVE WHEN MACHINE IS RUNNING.** Turn power **OFF** and allow all moving parts to come to a complete stop before leaving machine unattended.
11. **DO NOT USE IN DANGEROUS ENVIRONMENTS.** DO NOT use machinery in damp, wet locations, or where any flammable or noxious fumes may exist.
12. **KEEP WORK AREA CLEAN AND WELL LIGHTED.** Clutter and dark shadows may cause accidents.
13. **USE A GROUNDED EXTENSION CORD RATED FOR THE MACHINE AMPERAGE.** Grounded cords minimize shock hazards. Undersized cords create excessive heat. Always replace damaged extension cords.
14. **ALWAYS DISCONNECT FROM POWER SOURCE BEFORE SERVICING MACHINERY.** Make sure switch is in OFF position before reconnecting.
15. **MAINTAIN MACHINERY WITH CARE.** Keep blades sharp and clean for best and safest performance. Follow instructions for lubricating and changing accessories.
16. **MAKE SURE GUARDS ARE IN PLACE AND WORK CORRECTLY BEFORE USING MACHINERY.**
17. **REMOVE ADJUSTING KEYS AND WRENCHES.** Make a habit of checking for keys and adjusting wrenches before turning machinery **ON**.
18. **CHECK FOR DAMAGED PARTS BEFORE USING MACHINERY.** Check for binding or misaligned parts, broken parts, loose bolts, and any other conditions that may impair machine operation. Repair or replace damaged parts before operation.
19. **USE RECOMMENDED ACCESSORIES.** Refer to the instruction manual for recommended accessories. Improper accessories increase risk of injury.
20. **DO NOT FORCE MACHINERY.** Work at the speed for which the machine or accessory was designed.
21. **SECURE WORKPIECE.** Use clamps or a vise to hold the workpiece when practical. A secured workpiece protects your hands and frees both hands to operate the machine.
22. **DO NOT OVERREACH.** Maintain stability and balance at all times.
23. **MANY MACHINES CAN EJECT WORKPIECES TOWARD OPERATOR.** Know and avoid conditions that cause the workpiece to "kickback."
24. **ALWAYS LOCK MOBILE BASES (IF USED) BEFORE OPERATING MACHINERY.**
25. **CERTAIN DUST MAY BE HAZARDOUS** to the respiratory systems of people and animals, especially fine dust. Be aware of the type of dust you are exposed to and always wear a respirator designed to filter that type of dust.



## **WARNING**

# Additional Safety Instructions for Bandsaws

- 1. BLADE CONDITION.** Do not operate with dull, cracked or badly worn blade. Dull blades require more effort to use and are difficult to control. Inspect blades for cracks and missing teeth before each use.
- 2. HAND PLACEMENT.** Never position fingers or hands in line with the cut. Serious personal injury could occur.
- 3. GUARDS.** Do not operate this bandsaw without the blade guard in place.
- 4. BLADE REPLACEMENT.** When replacing blades, make sure teeth face toward the workpiece and the blade is properly tensioned before operating.
- 5. WORKPIECE HANDLING.** Never hold small workpieces with your fingers during a cut. Always support/feed the workpiece with push stick, table support, vise, or some type of clamping fixture.
- 6. CUTTING TECHNIQUES.** Plan your cuts so you always cut out of the wood. **DO NOT** back the workpiece away from the blade while the saw is running. If you need to back the work out, turn the bandsaw **OFF** and wait for the blade to come to a complete stop, and **DO NOT** twist or put excessive stress on the blade while backing work away.
- 7. BLADE SPEED.** Allow blade to reach full speed before cutting.
- 8. LEAVING WORK AREA.** Never leave a machine running and unattended. Allow the bandsaw to come to a complete stop before you leave it unattended.
- 9. FEED RATE.** Always feed stock evenly and smoothly. **DO NOT** force or twist blade while cutting, especially when sawing small radii.
- 10. WORKPIECE MATERIAL.** This machine is designed to cut wood only. It is not designed to cut metal or use cutting fluid.
- 11. MAINTENANCE/SERVICE.** All inspections, adjustments, and maintenance are to be done with the power **OFF** and the plug removed from the outlet. Wait for all moving parts to come to a complete stop.
- 12. BLADE CONTROL.** Do not attempt to stop or slow the blade with your hand or a workpiece. Allow the blade to stop on its own, unless your machine is equipped with a brake.
- 13. EXPERIENCING DIFFICULTIES.** If at any time you are experiencing difficulties performing the intended operation, stop using the machine! Contact our Technical Support Department at (570) 546-9663.

## **WARNING**

Like all machinery there is potential danger when operating this machine. Accidents are frequently caused by lack of familiarity or failure to pay attention. Use this machine with respect and caution to lessen the possibility of operator injury. If normal safety precautions are overlooked or ignored, serious personal injury may occur.

## **CAUTION**

No list of safety guidelines can be complete. Every shop environment is different. Always consider safety first, as it applies to your individual working conditions. Use this and other machinery with caution and respect. Failure to do so could result in serious personal injury, damage to equipment, or poor work results.



# SECTION 2: CIRCUIT REQUIREMENTS

## 220V Single-Phase

### **!WARNING**

Serious personal injury could occur if you connect the machine to the power source before you have completed the set up process. **DO NOT** connect the machine to the power source until instructed to do so.

### Amperage Draw

The Model G0636X motor draws the following amps under maximum load:

Motor Draw .....22 Amps

### Circuit Requirements

We recommend connecting your machine to a dedicated and grounded circuit that is rated for the amperage given below. Never replace a circuit breaker on an existing circuit with one of higher amperage without consulting a qualified electrician to ensure compliance with wiring codes. **If you are unsure about the wiring codes in your area or you plan to connect your machine to a shared circuit, consult a qualified electrician.**

Recommended Circuit Size.....30 Amps

### Plug/Receptacle Type

Recommended Plug/Receptacle....NEMA L6-30

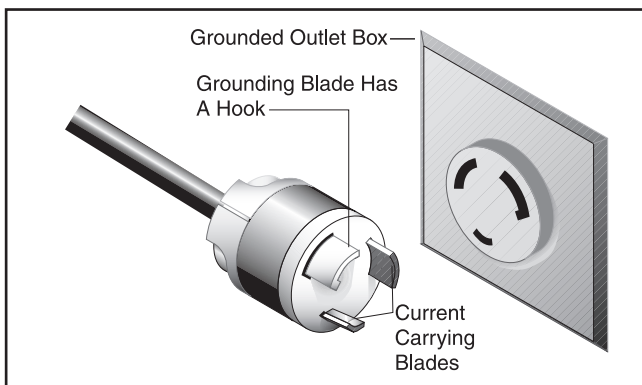
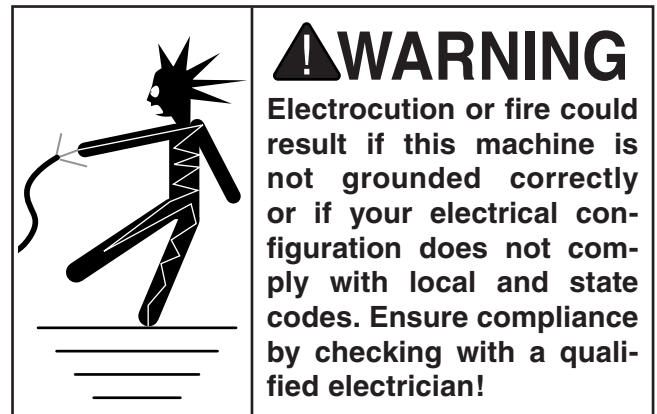


Figure 3. NEMA L6-30 plug and receptacle.

A cord is not provided because the style of cord used will vary depending upon the type of electrical service in each particular shop. We recommend installing a 12 gauge, 3 wire, 300VAC cord.

### Grounding

In the event of an electrical short, grounding reduces the risk of electric shock. The grounding wire in the power cord must be properly connected to the grounding prong on the plug; likewise, the outlet must be properly installed and grounded. All electrical connections must be made in accordance with local codes and ordinances.



### Extension Cords

We do not recommend the use of extension cords. Instead, arrange the placement of your equipment and the installed wiring to eliminate the need for extension cords.

If you find it absolutely necessary to use an extension cord at 220V with your machine:

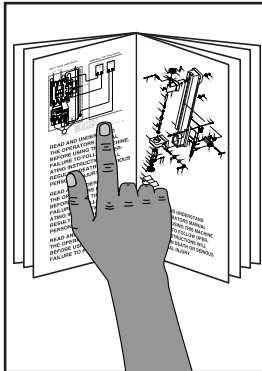
- Use at least a 10 gauge cord that does not exceed 50 feet in length!
- The extension cord must also contain a ground wire and plug pin.
- A qualified electrician **MUST** size cords over 50 feet long to prevent motor damage.





# SECTION 3: SETUP

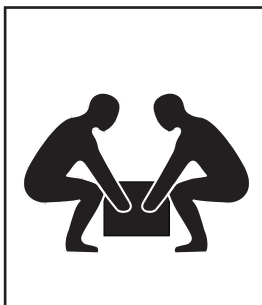
## Setup Safety



**!WARNING**  
 This machine presents serious injury hazards to untrained users. Read through this entire manual to become familiar with the controls and operations before starting the machine!



**!WARNING**  
 Wear safety glasses during the entire setup process!



**!WARNING**  
 This machine and its components are very heavy. Get lifting help or use power lifting equipment such as a fork lift to move heavy items.

## Items Needed for Setup

The following items are needed to complete the setup process, but are not included with your machine:

Description	Qty
• Safety Glasses (for each person) .....	1
• Machinist's Square .....	1
• Solvent Cleaner .....	As Needed
• Shop Rags .....	As Needed
• Feeler Gauge 0.016" .....	1
• Straightedge .....	1
• Fine Ruler .....	1
• Dust Collector .....	1
• Dust Hoses 4" .....	2
• Hose Clamps .....	2
• Forklift (1000 Lb Capacity) .....	1
• 1000 Lb Capacity Chain or Strap w/Hook..	1

## Unpacking

Your Model G0636X was carefully packaged for safe transportation. Remove the packaging materials from around your machine and inspect it. If you discover the machine is damaged, *please immediately call Customer Service at (570) 546-9663 for advice.*

Save the containers and all packing materials for possible inspection by the carrier or its agent. *Otherwise, filing a freight claim can be difficult.*

When you are completely satisfied with the condition of your shipment, inventory the contents.





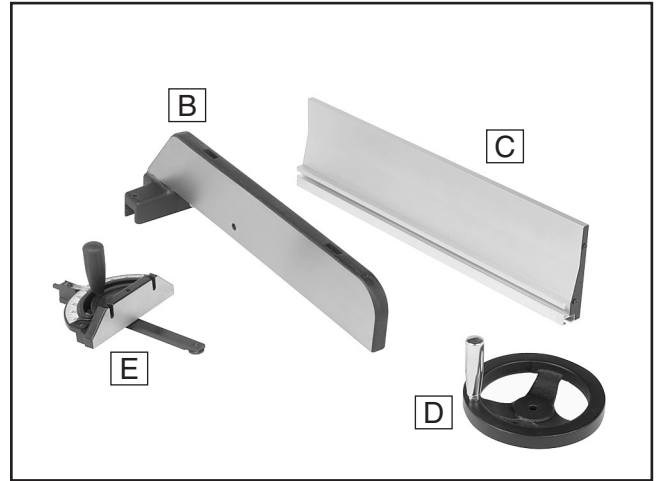
# Inventory

The following is a description of the main components shipped with your machine. Lay the components out to inventory them.

**Note:** *If you can't find an item on this list, check the mounting location on the machine or examine the packaging materials carefully. Occasionally we pre-install certain components for shipping purposes.*

<b>Crate Contents (Figure 4):</b>	<b>Qty</b>
A. Bandsaw (not shown).....	1
B. Cast Iron Fence Assembly .....	1
C. Resaw Fence .....	1
D. Guide Post Handwheel .....	1
E. Miter Gauge.....	1

<b>Hardware and Tools:</b>	<b>Qty</b>
• Eye Bolts M10-1.5 x 15.....	2
• Fence Handle M8-1.25 x 20 (Fence).....	1
• Hex Nut M8-1.25 (Fence).....	1
• Resaw Fence Lock Handle M8-1.25 x 44 (Resaw Fence).....	1
• Flat Washer M8-1.25 x 30 (Resaw Fence) 1	1
• Moving Plate (Resaw Fence).....	1
• Open End Wrench 10 x 13mm.....	1
• Open End Wrench 17 x 19mm.....	1
• Hex Wrench 5mm & 6mm.....	1 Ea
• Cap Screw M6-1 x 25 (Handwheel).....	1



**Figure 4.** G0636 crate contents.

If any nonproprietary parts are missing (e.g. a nut or a washer), we will gladly replace them; or for the sake of expediency, replacements can be obtained at your local hardware store.

	<p style="text-align: center;"><b>!WARNING</b></p> <p style="text-align: center;"><b>SUFFOCATION HAZARD!</b></p> <p><b>Immediately discard all plastic bags and packing materials to eliminate choking/suffocation hazards for children and animals.</b></p>
--	--



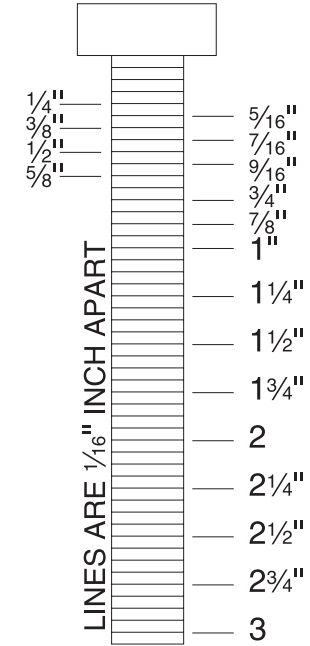
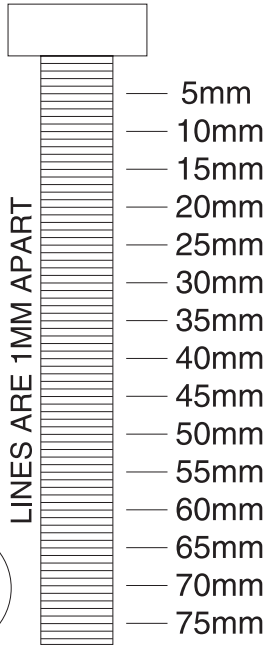
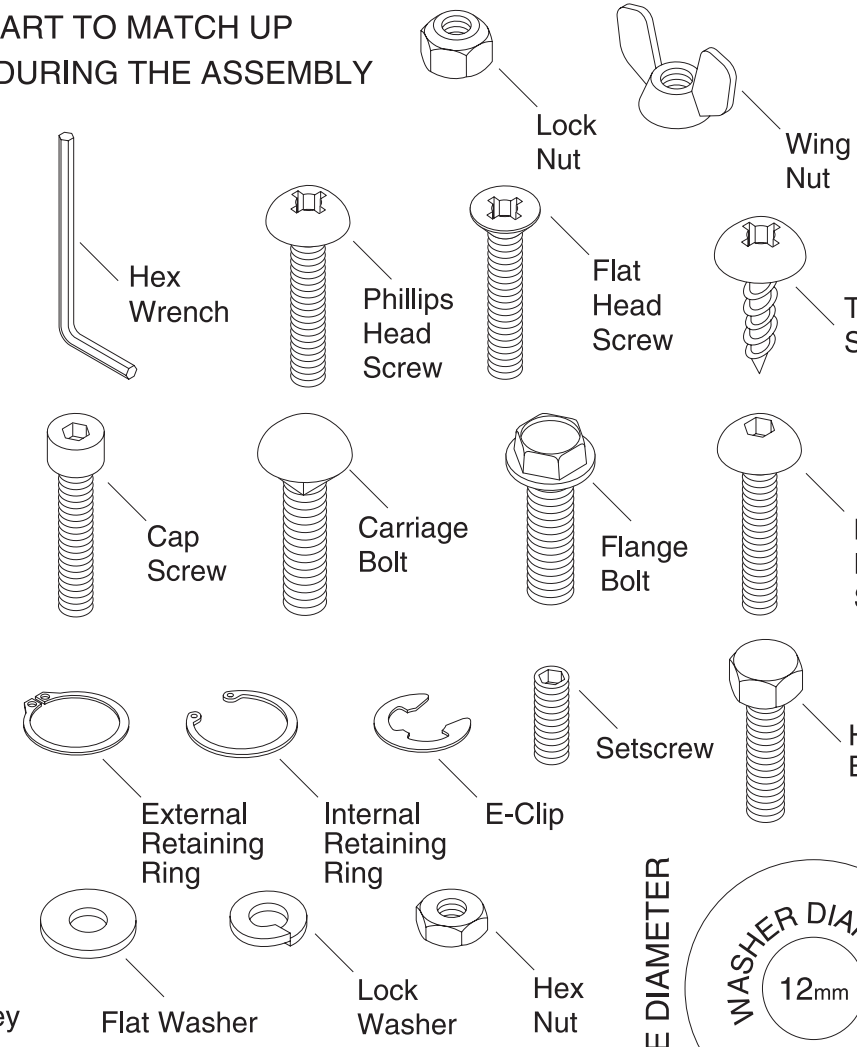
# Hardware Recognition Chart

USE THIS CHART TO MATCH UP HARDWARE DURING THE ASSEMBLY PROCESS.

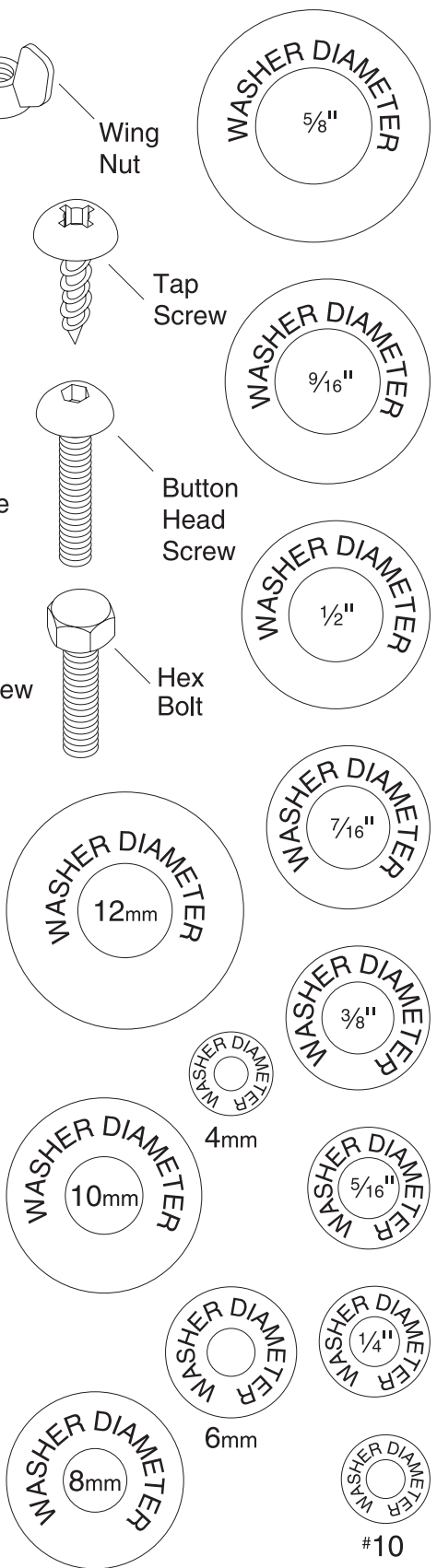
MEASURE BOLT DIAMETER BY PLACING INSIDE CIRCLE

- #10
- 1/4"
- 5/16"
- 3/8"
- 7/16"
- 1/2"

- 4mm
- 6mm
- 8mm
- 10mm
- 12mm
- 16mm




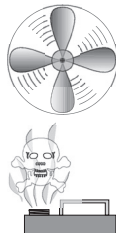
WASHERS ARE MEASURED BY THE INSIDE DIAMETER



# Clean Up

The unpainted surfaces are coated with a waxy oil to prevent corrosion during shipment. Remove this protective coating with a solvent cleaner or citrus-based degreaser such as Grizzly's G7895 Citrus Degreaser. To clean thoroughly, some parts must be removed. **For optimum performance from your machine, clean all moving parts or sliding contact surfaces.** Avoid chlorine-based solvents, such as acetone or brake parts cleaner that may damage painted surfaces. Always follow the manufacturer's instructions when using any type of cleaning product.

	<p><b>! WARNING</b> Gasoline and petroleum products have low flash points and can explode or cause fire if used to clean machinery. <b>DO NOT</b> use these products to clean the machinery.</p>
--	--

	<p><b>! CAUTION</b> Many cleaning solvents are toxic if inhaled. Minimize your risk by only using these products in a well ventilated area.</p>
---	---

## G7895—Grizzly Citrus Degreaser

This natural, citrus-based degreaser is a great solution for removing export grease, and it's much safer to work around than nasty solvents.

<p>Call <b>1-800-523-4777</b> To Order</p>	
--	---

Figure 5. Grizzly citrus degreaser.

# Site Considerations

## Floor Load

Refer to the **Machine Data Sheet** for the weight and footprint specifications of your machine. Some residential floors may require additional reinforcement to support both the machine and operator.

## Placement Location

Consider existing and anticipated needs, size of material to be processed through each machine, and space for auxiliary stands, work tables or other machinery when establishing a location for your new machine. See **Figure 6** for the minimum working clearances.

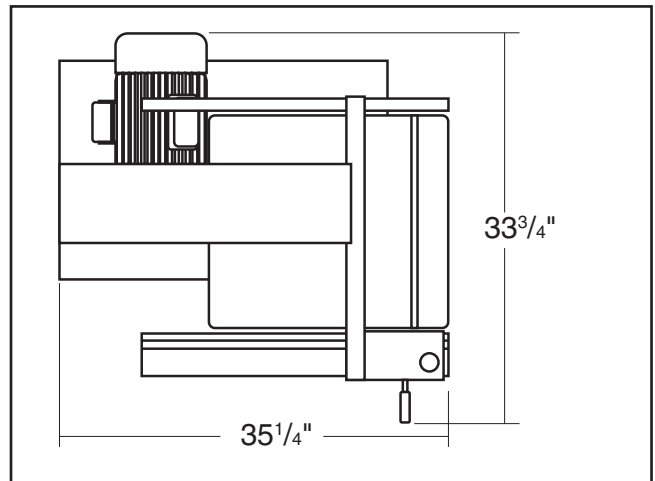
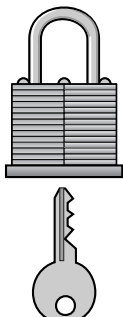


Figure 6. Minimum working clearances.

	<p><b>! CAUTION</b> Children and visitors may be seriously injured if unsupervised around this machine. Lock entrances to the shop or disable start switch or power connection to prevent unsupervised use.</p>
--	---



# Moving & Placing Base Unit

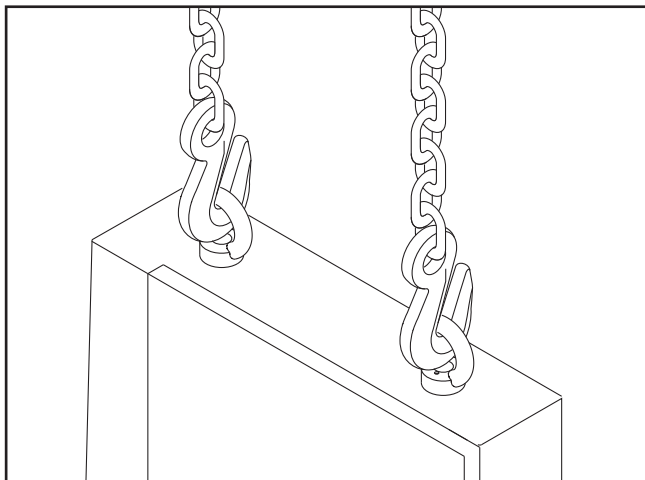
## **!WARNING**

This is an extremely heavy machine. Serious personal injury may occur if safe moving methods are not followed. To be safe, you will need assistance and a forklift or a hoist when removing the machine from the crate. Use a chain or a lifting strap with a minimum of 1000 lbs. lifting capacity. If the chain or lifting strap breaks, serious personal injury may occur.

Take special care when moving this bandsaw. Only use the following methods to lift or move this bandsaw.

### To move and place the bandsaw:

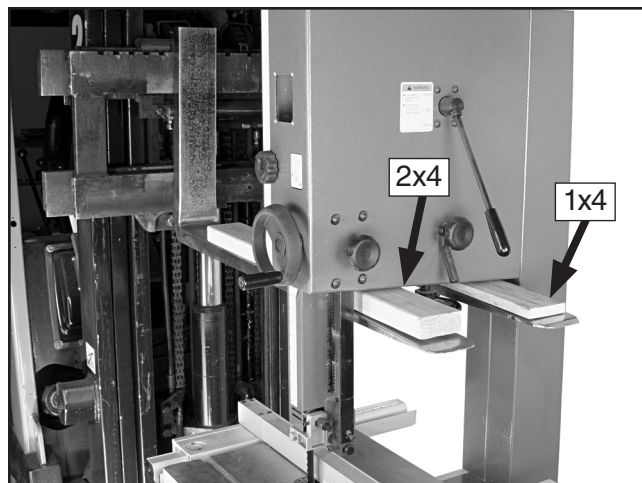
1. Use a forklift to move the bandsaw on the pallet to its final location.
2. Unbolt the bandsaw from the pallet.
3. Install the eye bolts shown in **Figure 7**, making sure they are threaded all the way in, then place the lifting hooks through the eye bolts and lift slowly with a forklift.
4. Remove the pallet and slowly set the bandsaw into position.



**Figure 7.** Lifting the bandsaw.

To move and place the bandsaw using wood shims:

1. Use a forklift to move the bandsaw on the pallet to its final location.
2. Carefully place the forklift forks under the head and install a 1x4 shim between the head and the left fork and a 2x4 shim between the head and right fork so the bandsaw is level, as shown in **Figure 8**.
3. Unbolt the bandsaw from the pallet.



**Figure 8.** Example of lifting bandsaw with forklift using wood shims.

4. Lift the bandsaw off of the pallet, remove the pallet, and slowly set the bandsaw into position.

**Note:** If you are concerned about your forklift forks hitting the tension handwheel, remove the handwheel, then reinstall it after lifting.



# Mounting to Shop Floor

Although not required, we recommend that you mount your new machine to the floor. Because this is an optional step and floor materials may vary, floor mounting hardware is not included. However, you must level your machine with a precision level.

You may also mount your machine to a mobile base (see **Figure 10**) that has wheel locking or wheel retracting capabilities that keep the mobile base from rolling when the bandsaw is in use. We recommend using the Grizzly Model G7315 mobile base.

## Bolting to Concrete Floors

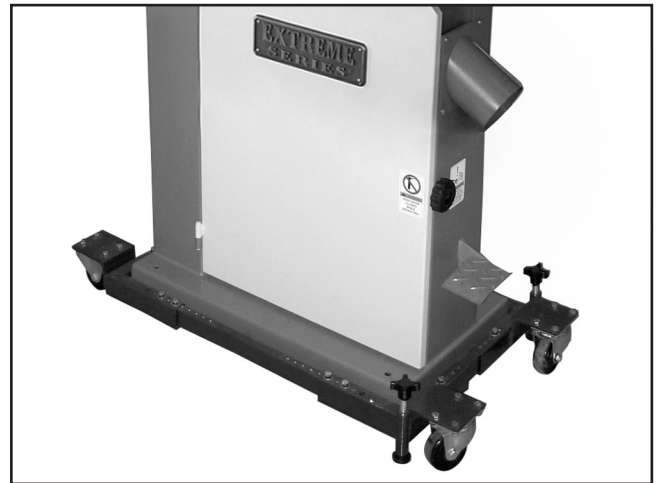
Lag shield anchors with lag bolts (**Figure 9**) and anchor studs are two popular methods for anchoring an object to a concrete floor. We suggest you research the many options and methods for mounting your machine and choose the best that fits your specific application.

### **NOTICE**

**Anchor studs are stronger and more permanent alternatives to lag shield anchors; however, they will stick out of the floor, which may cause a tripping hazard if you decide to move your machine.**



**Figure 9.** Typical fasteners for mounting to concrete floors.

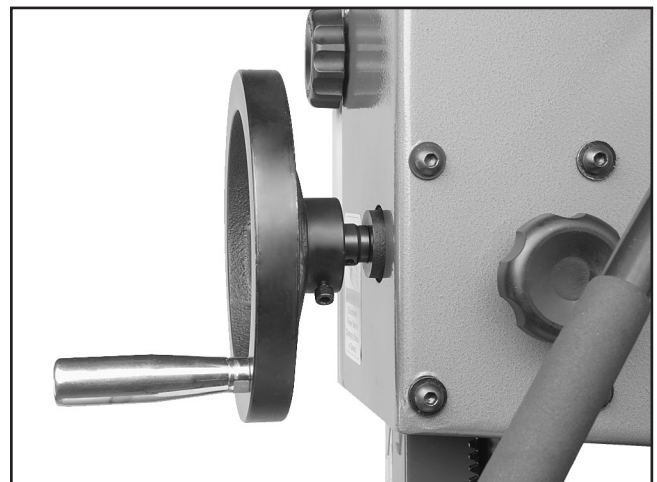


**Figure 10.** Bandsaw mounted on G7315 mobile base.

# Guide Post Handwheel

**To install the guide post handwheel:**

1. Insert the guide post handwheel onto the shaft, and secure it with the cap screw on the flat side of the shaft, as shown in **Figure 11**.

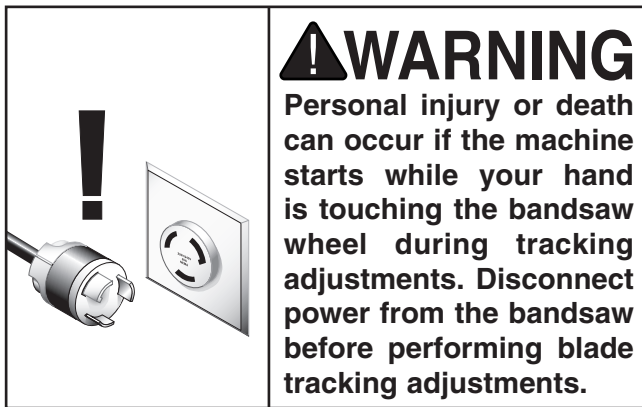


**Figure 11.** Guide post handwheel installed.





# Blade Tracking

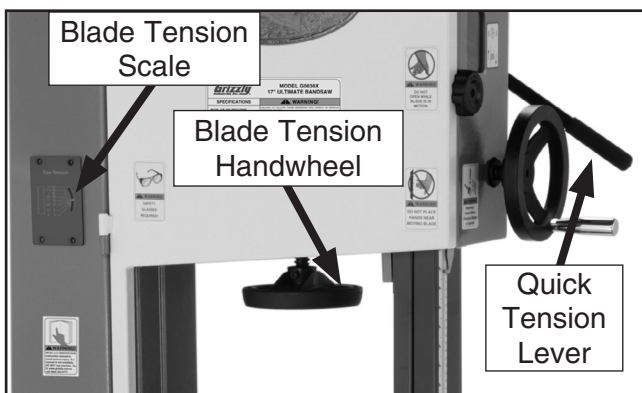


The blade tracking is primarily affected by the tilt of the upper wheel, also known as "Center Tracking"; and the alignment of both wheels, also known as "Coplanar Tracking." (For Coplanar Tracking, see the **Wheel Alignment** instructions on **Page 46**.)

The wheels on this bandsaw were aligned at the factory, so Center Tracking is the only adjustment that needs to be performed when the saw is new.

## To center track the blade:

1. DISCONNECT BANDSAW FROM POWER!
2. Make sure the upper and lower blade guides are adjusted away from the blade (see **Page 21**).
3. Move the quick tension lever to the tightened position and turn the blade tension handwheel until the blade tension matches the mark on the blade tension scale for the appropriate blade thickness (**Figure 12**).

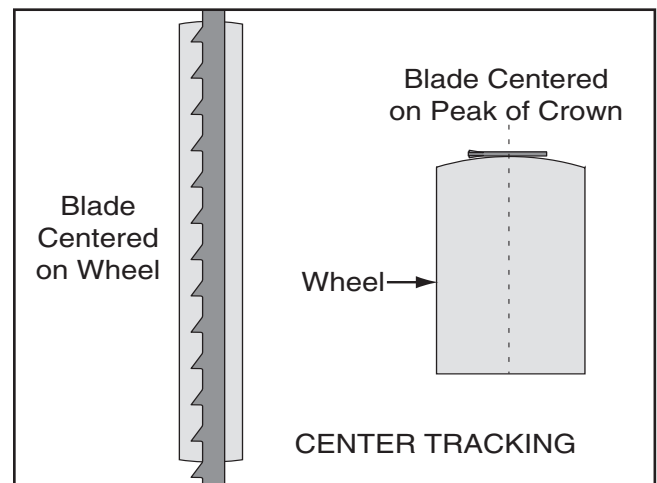


**Figure 12.** Blade tensioning controls.

4. Open the upper wheel cover.
5. Spin the upper wheel by hand at least three times and watch how the blade rides on the crown of the wheel. Refer to **Figure 13** for an illustration of this concept.

—If the blade rides in the center of the upper wheel and is centered on the peak of the wheel crown, then the bandsaw is already center tracked properly and no further adjustments are needed at this time.

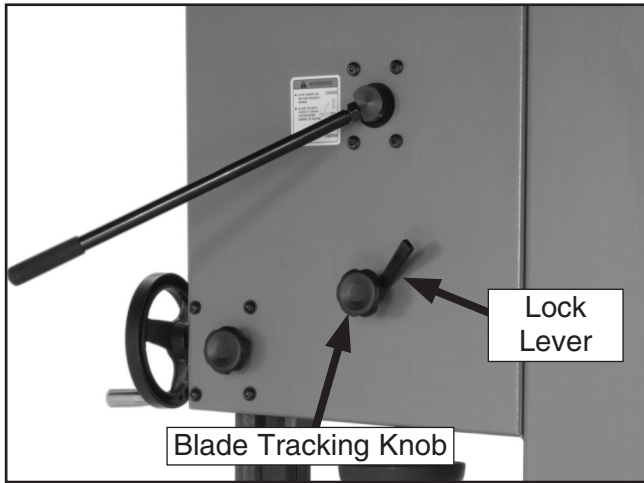
—If the blade does not ride in the center of the upper wheel and is not centered on the peak of the wheel crown, then continue with the following steps.



**Figure 13.** Center tracking profiles.



- Loosen the lock lever (**Figure 14**) so that the blade tracking knob can rotate.



**Figure 14.** Blade tracking controls.

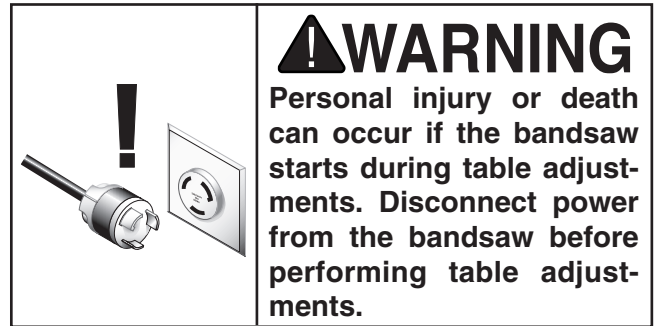
- Spin the upper wheel with one hand and rotate the blade tracking knob with the other hand to make the blade ride in the center of the bandsaw wheel tire.
- Tighten the lock lever and close the upper wheel cover.

*For the best performance from your saw, regularly maintain proper tracking of the blade.*

## **NOTICE**

**Changes in the blade tension may change the blade tracking.**

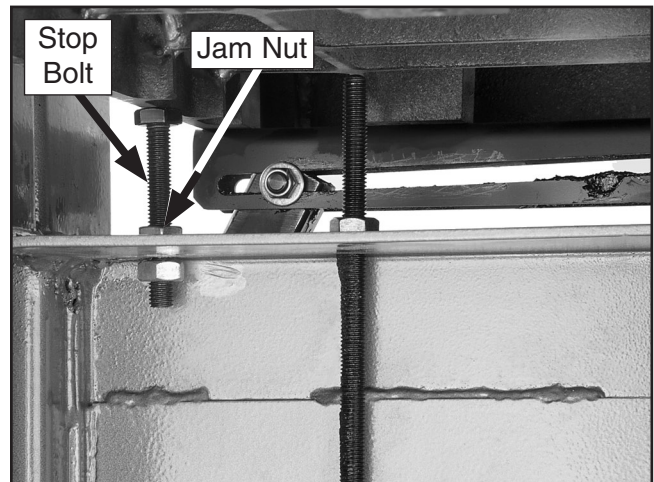
## Positive Stop



The positive stop allows the table to be quickly and accurately returned to the horizontal (0°) position after being adjusted to a different angle.

### To set the positive stop:

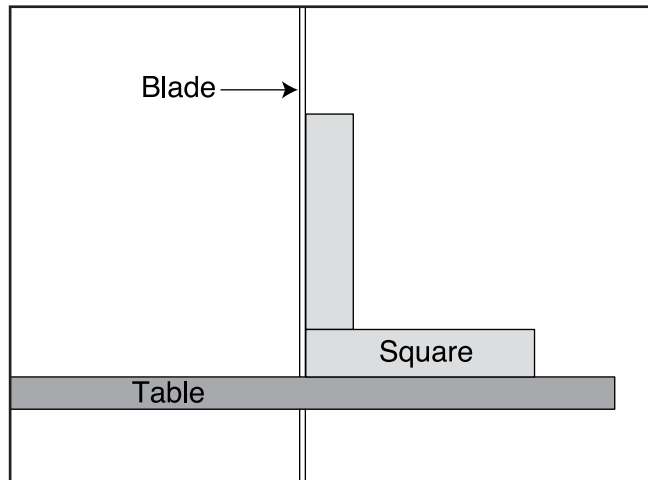
- DISCONNECT BANDSAW FROM POWER!
- Adjust the blade tension to the appropriate level for the blade size on the blade tension scale (see **Page 21**).
- Loosen the jam nut that locks the positive stop bolt in place.



**Figure 15.** Positive stop bolt and jam nut (as viewed from front).



4. Raise the guide post and place a machinist's square on the table next to the side of the blade as illustrated in **Figure 16**. Adjust the table square with the blade using the table tilt handwheel, then secure with the table tilt lock lever.



**Figure 16.** Squaring table to blade.

5. Adjust the positive stop bolt so it just touches the table and secure it by tightening the jam nut against the bandsaw.
6. Check the adjustment for accuracy once you have tightened the jam nut.
7. Loosen the screw on the table tilt scale pointer, but do not remove it.
8. Align the tip of the pointer with the 0° mark on the table tilt scale, then tighten the screw to secure the setting.

## Dust Collection

### **CAUTION**

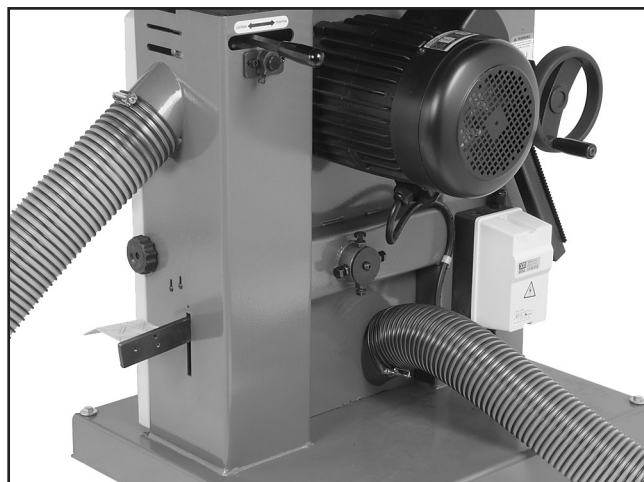
**DO NOT** operate the Model G0636X without an adequate dust collection system. This saw creates substantial amounts of wood dust while operating. Failure to use a dust collection system can result in short and long-term respiratory illness.

#### **Recommended CFM at each Dust Port: 400**

*Do not confuse this CFM recommendation with the rating of the dust collector. To determine the CFM at the dust port, you must consider these variables: (1) CFM rating of the dust collector, (2) hose type and length between the dust collector and the machine, (3) number of branches or wyes, and (4) amount of other open lines throughout the system. Explaining how to calculate these variables is beyond the scope of this manual. Consult an expert or purchase a good dust collection "how-to" book.*

#### **To connect a dust collection hose:**

1. Fit a 4" dust hose over each dust port, as shown in **Figure 17**, and secure in place with a hose clamp.
2. Tug each hose to make sure it does not come off. **Note:** A tight fit is necessary for proper performance.



**Figure 17.** Dust hoses attached to dust port.

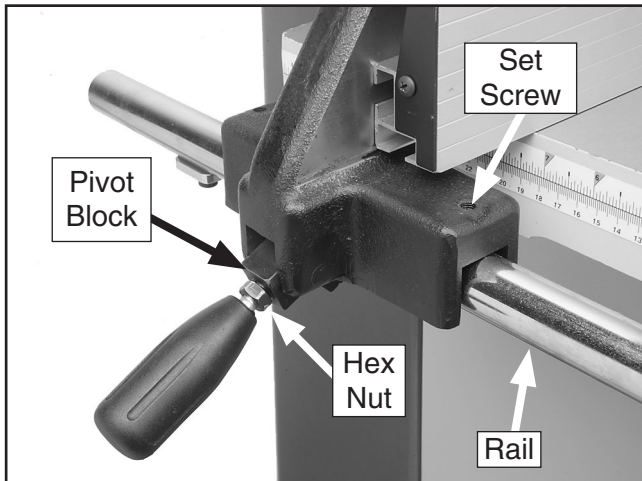




# Fence

## To install the fence handle:

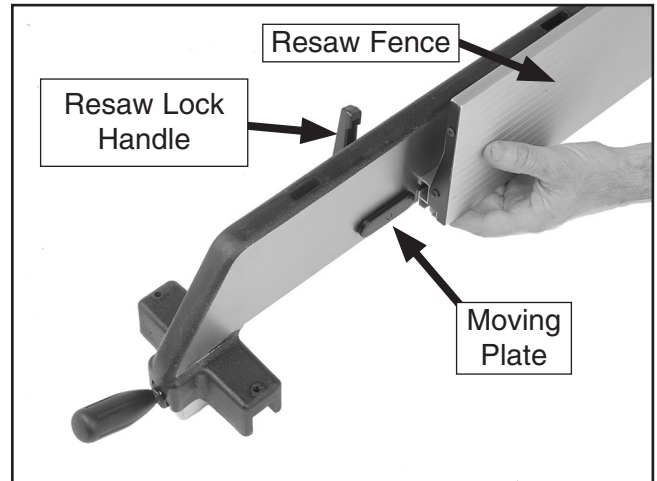
1. Thread the fence handle onto the fence, as shown in **Figure 18**, and tighten the hex nut against the fence pivot block to secure the handle.



**Figure 18.** Fence handle installed.

2. Install the resaw fence lock handle (with the washer and moving plate) onto the fence, then slide the resaw fence over the moving plate as shown in **Figure 19**.

**Note:** Leave the moving plate and lock handle loose enough to slide on the resaw fence.



**Figure 19.** Attaching resaw fence to standard fence.

3. Tighten the resaw lock handle.
4. Pull the fence handle up and place the fence assembly on the rail, as shown in **Figure 18**.
5. Push the fence handle down to lock the fence assembly in place.



# Test Run

Once the assembly is complete, test run your machine to make sure it runs properly and is ready for regular operation.

The test run consists of verifying the following: 1) The motor powers up and runs correctly, 2) the safety disabling mechanism on the switch works correctly, and 3) the stop button safety feature works correctly.

If, during the test run, you cannot easily locate the source of an unusual noise or vibration, stop using the machine immediately, then review **Troubleshooting** on **Page 42**.

If you still cannot remedy a problem, contact our Tech Support at (570) 546-9663 for assistance.

## To test run the machine:

1. Make sure you have read the safety instructions at the beginning of the manual and that the machine is setup properly.
2. Make sure all tools and objects used during setup are cleared away from the machine.
3. Connect the machine to the power source.
4. Verify that the machine is operating correctly by turning the switch disabling key (**Figure 20**) to "1" and turning the machine **ON**.

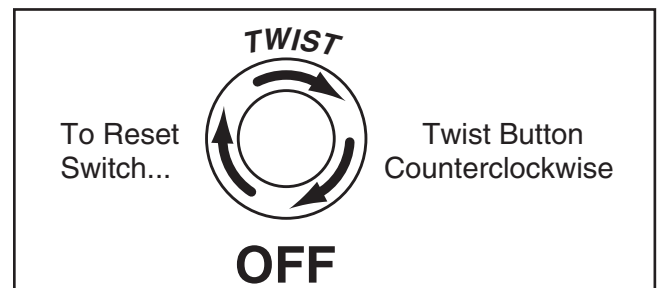
—When operating correctly, the machine runs smoothly with little or no vibration or rubbing noises.

—Investigate and correct strange or unusual noises or vibrations before operating the machine further. Always disconnect the machine from power when investigating or correcting potential problems.



**Figure 20.** G0636X switch disabling key and ON/OFF switch.

5. Press the OFF button to stop the machine.
6. WITHOUT resetting the OFF button, press the ON button. The machine should not start.
  - If the machine does not start, the OFF button safety feature is working correctly.
  - If the machine does start (with the stop button pushed in), immediately disconnect power to the machine. The OFF button safety feature is not working correctly. This safety feature must work properly before proceeding with regular operations. Call Tech Support for help.
7. Push the OFF button in, then twist it clockwise so it pops out. When the OFF button pops out, the switch is reset and ready for operation (see **Figure 21**).



**Figure 21.** Resetting the switch.

8. Turn the switch disabling key to "0", as shown in **Figure 20**.



9. Try to turn the machine **ON**.
  - If the bandsaw does not start, the switch disabling feature is working as designed. The Test Run is complete.
  - If the bandsaw starts, immediately disconnect power. The switch disabling feature is not working correctly. This safety feature must work properly before proceeding with regular operations. Call Tech Support for help.

---

## Tensioning Blade

---

A properly tensioned blade is essential for making accurate cuts and is required before making many bandsaw adjustments. (Everytime you replace the blade, you should perform this procedure because all blades tension differently.)

### To tension the bandsaw blade:

1. Complete the **Test Run** procedure and make sure the blade is tracking properly (see **Page 16**).
2. Raise the upper blade guide assembly as high as it will go, and adjust the upper and lower guide blocks as far away from the blade as possible (see **Adjusting Blade Guide Bearings**).

**Note:** *This procedure will NOT work if the guide blocks have any contact with the blade.*

3. Move the quick tension lever to the tightened position and turn the blade tension handwheel until the blade tension matches the mark on the blade tension scale for the appropriate blade thickness (See **Figure 12, Page 16**).
4. Turn the bandsaw **ON**.
5. Slowly release the tension one quarter of a turn at a time. When you see the bandsaw blade start to flutter, stop decreasing the tension.

6. Now, slowly increase the tension until the blade stops fluttering, then tighten the tension another quarter turn.
7. Look at what the blade tension scale reads and use that as a guide for tensioning that blade in the future.

**Note:** *Always release blade tension after use to increase blade life and reduce strain on the bandsaw components.*
8. Re-adjust the blade tracking as instructed on **Page 16**.

---

## Adjusting Blade Guide Bearings

---

The blade guides provide side-to-side support to keep the blade straight while cutting. The blade guides are designed to be adjusted in two ways—forward/backward and side-to-side.

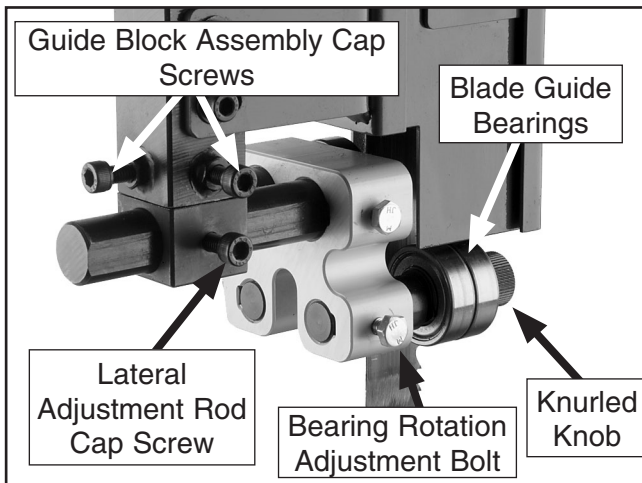
### To adjust the upper blade guides:

1. Make sure the blade is tracking properly and that it is correctly tensioned.
2. **DISCONNECT BANDSAW FROM POWER!**

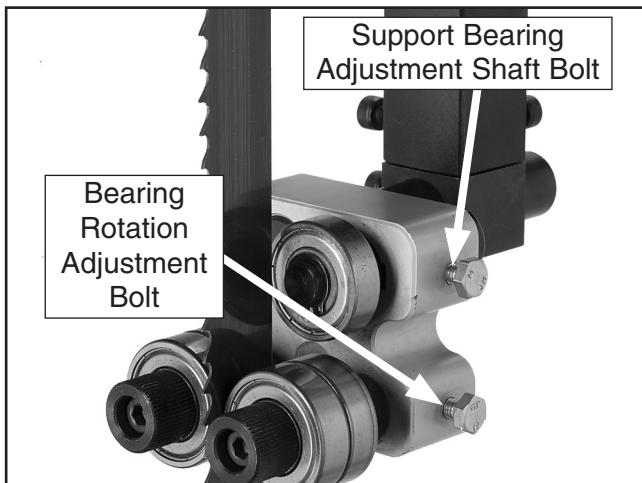
Continued on next page 



3. Familiarize yourself with the blade guide controls shown in **Figure 22 & 23**.



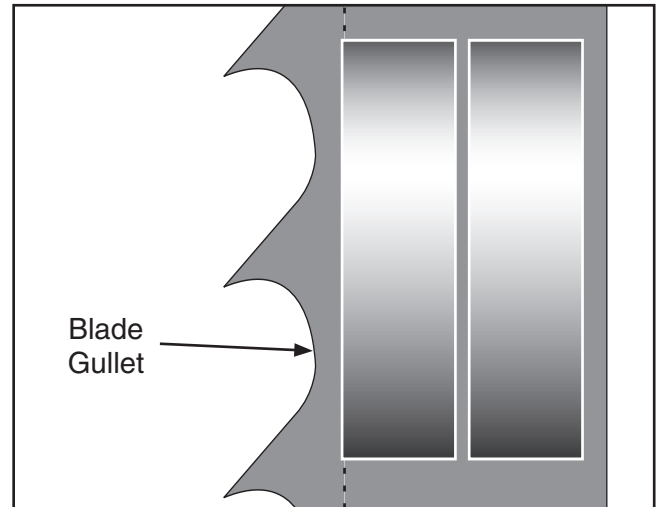
**Figure 22.** Upper blade guide controls (rear view).



**Figure 23.** Upper blade guide controls (front view).

4. Loosen the lateral adjustment rod cap screw, loosen the support bearing adjustment shaft bolt, and adjust the blade guides until the edges of the bearings are  $\frac{1}{16}$ " behind the blade gullets, as illustrated in **Figure 24**.

**Note:** The  $\frac{1}{16}$ " spacing is ideal, although with larger blades it may not be possible. In such cases, adjust the guide bearings as far forward to the blade gullets as possible, and still maintain the proper support bearing spacing adjustment.



**Figure 24.** Lateral adjustment of blade guides.

## **NOTICE**

**Make sure that the blade teeth will not contact the guide bearings when the blade is against the rear support bearing during the cut or the blade teeth will be ruined.**

5. Tighten the lateral adjustment rod cap screw.
6. Loosen the bearing rotation adjustment bolts on both sides of the blade.
7. Rotate the knurled knobs to position the bearings 0.004" away from the blade.

**Note:** 0.004" is approximately the thickness of a dollar bill.

8. Tighten both of the the bearing rotation adjustment bolts to lock the blade guide bearings in position.

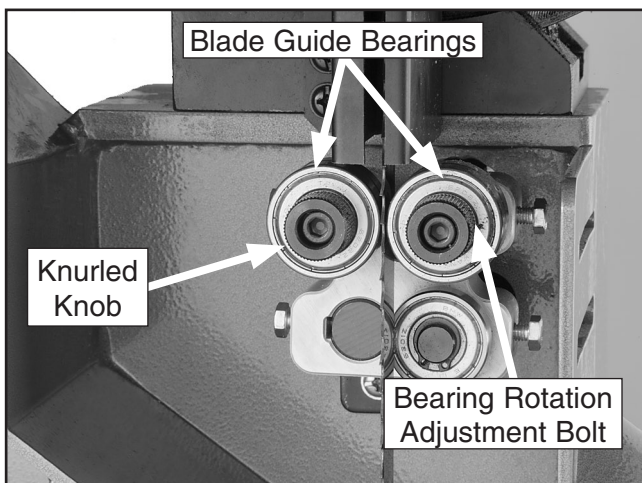


## NOTICE

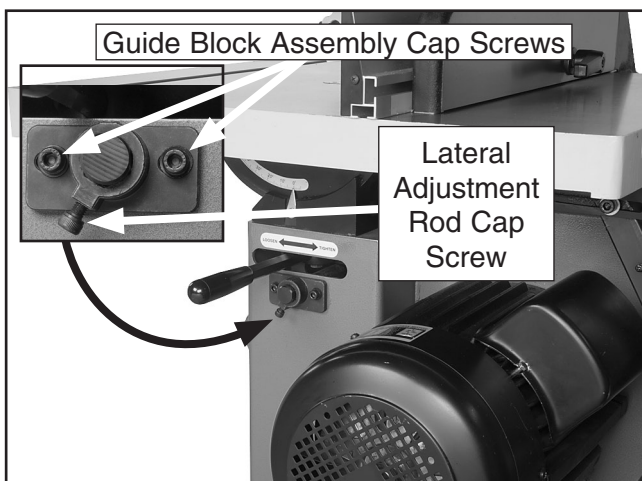
Whenever changing a blade or adjusting tension and tracking, the upper and lower blade support bearings and guide bearings must be properly adjusted and locked before cutting operations.

### To adjust the lower blade guides:

1. Make sure the blade is tracking properly and that it is correctly tensioned.
2. DISCONNECT BANDSAW FROM POWER!
3. Familiarize yourself with the blade guide controls shown in **Figure 25**.



**Figure 25.** Lower blade guide controls (front view).



**Figure 26.** Lower blade guide controls (rear view).

4. Follow the procedure for adjusting the upper blade guides on **Page 21**.

**Note:** The lateral adjustment rod cap screw and guide block assembly cap screws are located below the table tilt lock lever (see **Figure 26**).

## Adjusting Support Bearings

### NOTICE

Whenever changing a blade or adjusting tension and tracking, the upper and lower blade support bearings and blade guide bearings must be properly adjusted before cutting operations.

The support bearings are positioned behind the blade for support during cutting operations. Proper adjustment of the support bearings is an important part of making accurate cuts and also keeps the blade teeth from coming in contact with the guide bearings while cutting.

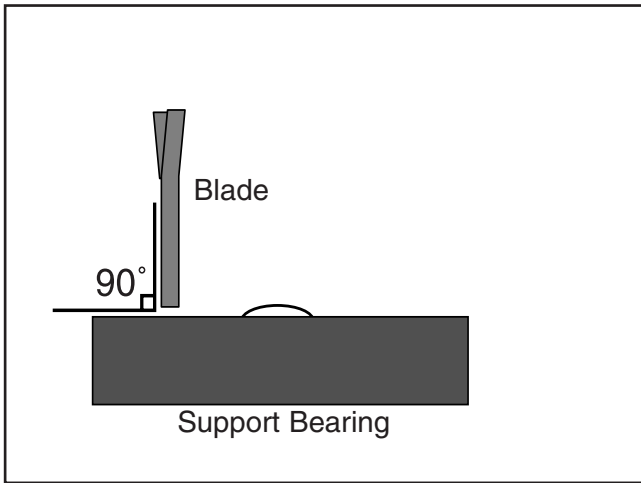
### To adjust the upper support bearing:

1. Make sure the blade is tracking properly and that it is correctly tensioned.
2. DISCONNECT BANDSAW FROM POWER!
3. Familiarize yourself with the upper support bearing controls shown in **Figure 22 & 23**.



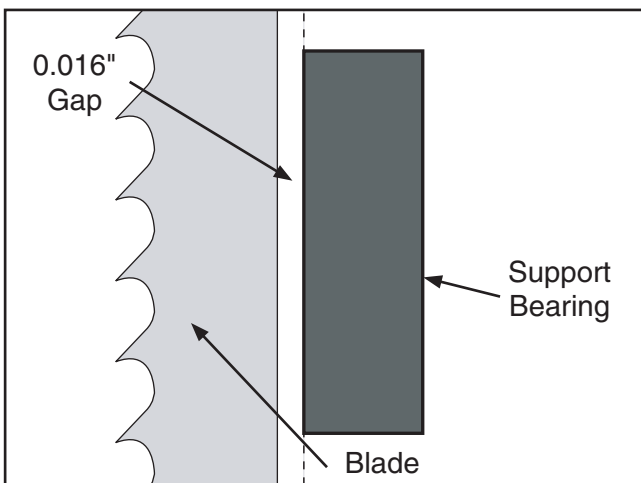


- Loosen the guide block assembly cap screws and rotate the blade guide assembly side-to-side, until the blade is perpendicular with the face of the support bearing, as illustrated in **Figure 27**.



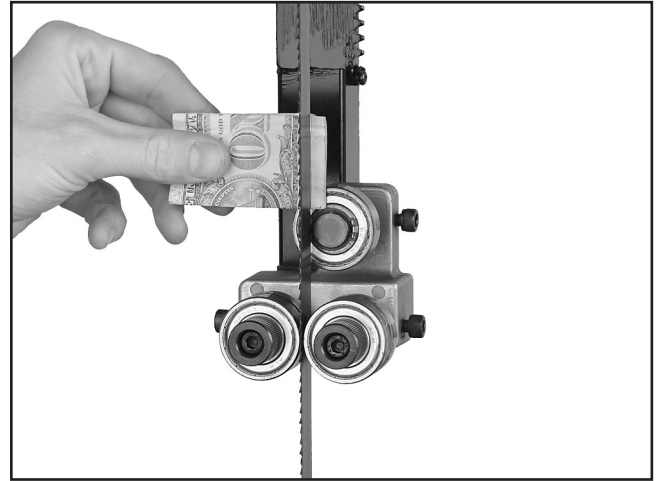
**Figure 27.** Illustration of blade set perpendicular (90°) to the support bearing face.

- Tighten the guide block assembly cap screws.
- Loosen the bolt on the support bearing adjustment shaft—if it is not already loose.
- Using a feeler gauge between the support bearing and the blade, position the bearing 0.016" away from the back of the blade, as illustrated in **Figure 28**.



**Figure 28.** Blade aligned 0.016" away from the bearing edge.

**Note:** For a quick gauge, fold a crisp dollar bill in half twice (four thicknesses of a dollar bill is approximately 0.016") and place it between the support bearing and the blade as shown in **Figure 29**.

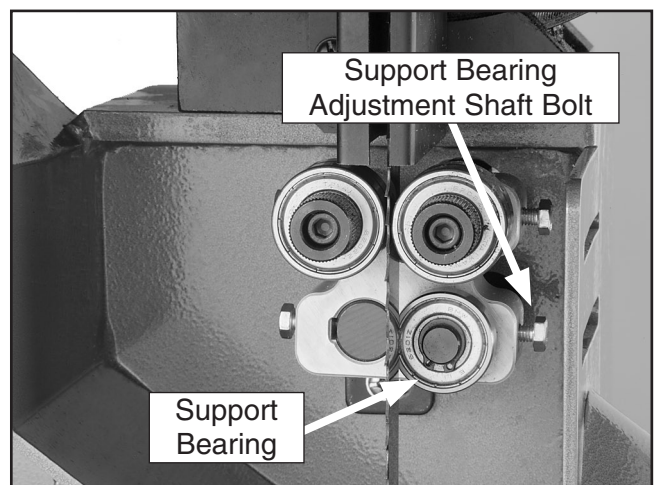


**Figure 29.** Example of dollar bill folded twice to make an approximate 0.016" gauge.

- Tighten the bolt to keep the support bearing locked in place.

**To adjust the lower support bearing:**

- Make sure the blade is tracking properly and is correctly tensioned.
- DISCONNECT BANDSAW FROM POWER!**
- Familiarize yourself with the lower support bearing controls shown in **Figure 30**.



**Figure 30.** Lower support bearing controls.

- Open the upper and lower wheel covers.



5. Make sure that the blade is perpendicular to the face of the support bearing, as illustrated in **Figure 27**.

—If the blade is perpendicular to the face of the support bearing, continue on to the next step.

—If the blade is not perpendicular to the support bearing, loosen the lateral adjustment rod cap screw and guide block assembly cap screws (**Figure 26**) and rotate the assembly side-to-side until it is perpendicular to the face of the support bearing, then re-tighten the cap screws.

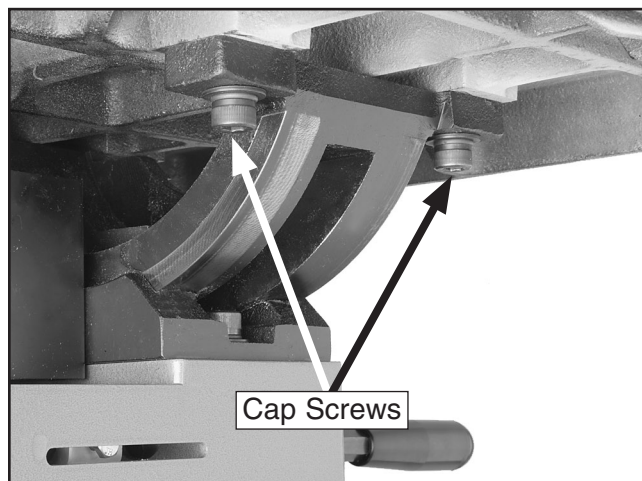
6. Loosen the bolt on the support bearing adjustment shaft.
7. Using a feeler gauge, position the bearing 0.016" away from the back of the blade, as illustrated in **Figure 28**, or use a dollar bill, as shown in **Figure 29**.
8. Tighten the bolt to keep the support bearing locked in place.

## Aligning Table

To ensure cutting accuracy, the table should be aligned so that the miter slot is parallel to the bandsaw blade. This procedure works best with a 1 $\frac{3}{8}$ " blade installed.

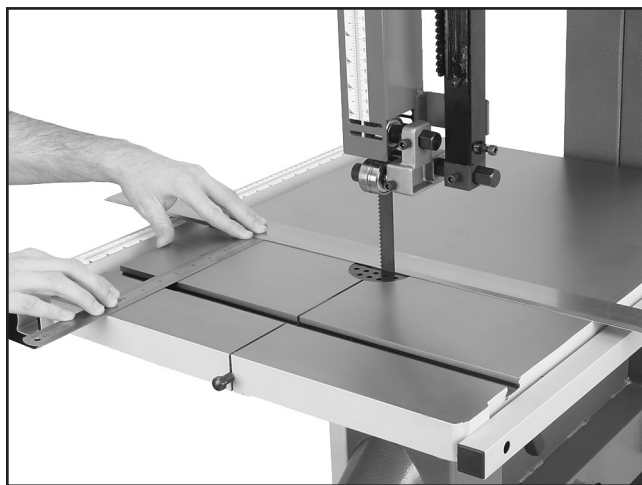
**To align the table so the miter slot is parallel to the bandsaw blade:**

1. Make sure that the blade is tracking properly and that it is correctly tensioned.
2. **DISCONNECT BANDSAW FROM POWER!**
3. Loosen the four trunnion cap screws that secure the table to the trunnions (**Figure 31**).



**Figure 31.** Cap screws securing table to trunnion.

4. Place an accurate straightedge along the blade. The straightedge should lightly touch both the front and back of the blade. **Note:** *Make sure the straightedge does not go across a tooth.*
5. Use a fine ruler to accurately gauge the distance between the straightedge and the miter slot. The distance you measure should be the same at both the front and the back of the table (see **Figure 32**).
6. Adjust the table as needed for proper alignment.
7. Tighten the trunnion cap screws when the alignment is correct.



**Figure 32.** Example of measuring for miter slot to be parallel with blade.

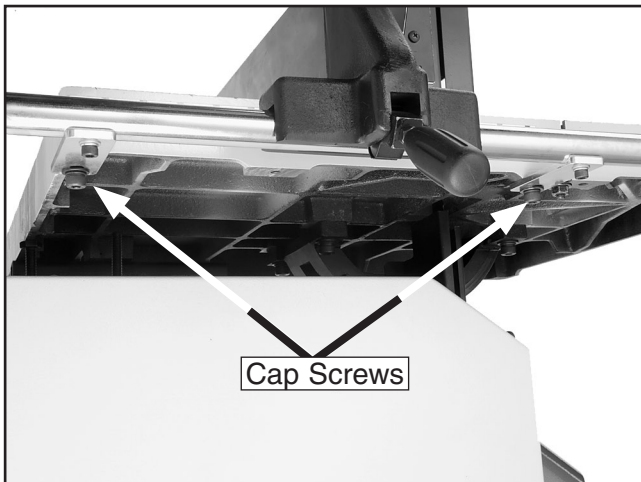


# Aligning Fence

To ensure cutting accuracy when the fence is first installed, the fence should be aligned with the miter slot.

**To align the fence parallel with the miter slot:**

1. DISCONNECT BANDSAW FROM POWER!
2. Make sure the miter slot is aligned with the bandsaw blade (see **Page 25**).
3. If the fence is mounted on the left-hand side of the blade, remove it and remount it next to the miter slot.
4. Loosen the two cap screws that secure the rail to the table (**Figure 33**).



**Figure 33.** Cap screws securing rail to table.

5. Adjust the fence face parallel with the edge of the miter slot, as shown in **Figure 34**.



**Figure 34.** Example of fence square with miter slot.

6. Tighten the two cap screws that secure the rail to the table, being careful not to move the fence.

## ***NOTICE***

Adjusting the fence parallel to the miter slot does not guarantee straight cuts. The miter slot may need to be adjusted parallel to the side of the blade. Refer to the "Aligning Table" instructions on Page 25.





# Pointer Calibration

Your new bandsaw is equipped with a fence measurement system that includes a fence pointer, which must be calibrated when the bandsaw is first set up.

## To calibrate the pointer:

1. If the fence is mounted on the right-hand side of the blade, remove it and re-install it on the left-hand side of the blade.
2. Place the fence flush against the bandsaw blade (**Figure 35**).



**Figure 35.** Example of fence flush with blade.

3. Loosen the pointer adjustment screw (**Figure 36**) and set the pointer in line with "0" and the measurement scale on the table.



**Figure 36.** Fence pointer adjustment screw.

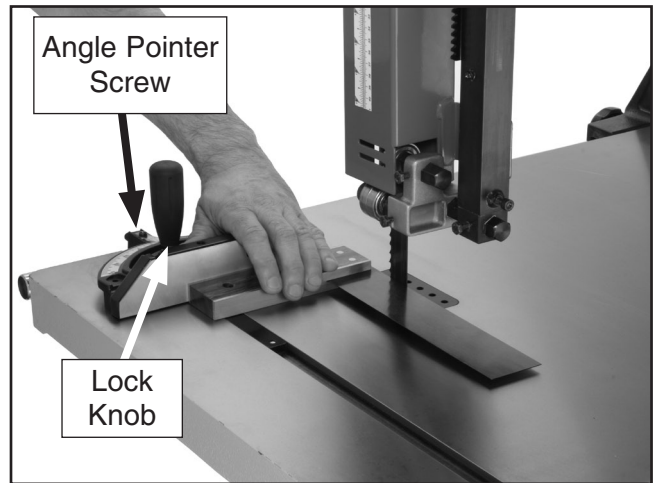
4. Tighten the pointer adjustment screw.

# Miter Gauge

The miter gauge needs to be calibrated to the blade when it is first mounted in the miter slot.

## To calibrate the miter gauge:

1. Place one edge of a machinist's square against the face of the miter gauge and the other against the blade face, as shown in **Figure 37**.



**Figure 37.** Example of squaring miter gauge to blade.

2. Loosen the lock knob on the miter gauge and adjust the gauge flush with the edge of the square.
3. Tighten the lock knob, and verify the setting.

**Note:** Sometimes the tightening procedure can affect the adjustment.

4. Loosen the screw that secures the angle pointer and adjust the pointer to the 0° mark on the scale.
5. Retighten the screw that secures the angle pointer.



# SECTION 4: OPERATIONS

## Operation Safety

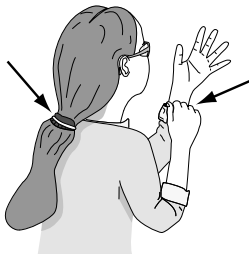
### **!WARNING**

Damage to your eyes and lungs could result from using this machine without proper protective gear. Always wear safety glasses and a respirator when operating this machine.



### **!WARNING**

Loose hair and clothing could get caught in machinery and cause serious personal injury. Keep loose clothing and long hair away from moving machinery.



### **NOTICE**

If you have never used this type of machine or equipment before, **WE STRONGLY RECOMMEND** that you read books, trade magazines, or get formal training before beginning any projects. Regardless of the content in this section, Grizzly Industrial will not be held liable for accidents caused by lack of training.

## Overview

The bandsaw is one of the most versatile wood cutting tools in the shop. It is capable of performing many different cutting functions including:

### Straight Cuts

- Miters
- Angles
- Compound Angles
- Resawing
- Ripping
- Crosscutting

### Irregular Cuts

- Simple and Complex Curves
- Duplicate Parts
- Circles
- Beveled Curves

A properly adjusted and tuned bandsaw can be safer to operate than most other saws and performs many functions with ease and accuracy.

### Basic Cutting Tips

Here are some basic tips to follow when operating the bandsaw:

- Replace, sharpen, and clean blades as necessary and make adjustments periodically to keep the saw always running in top condition.
- Use light and even pressure while cutting. Light contact with the blade will permit easier line following and prevent undue friction.
- Avoid trying to turn tight corners because this will twist the blade. Remember, you must saw around corners.
- Misuse of the saw or using incorrect techniques is unsafe and results in frustration and poor cuts. Remember—the blade does the cutting with the operator's guidance.

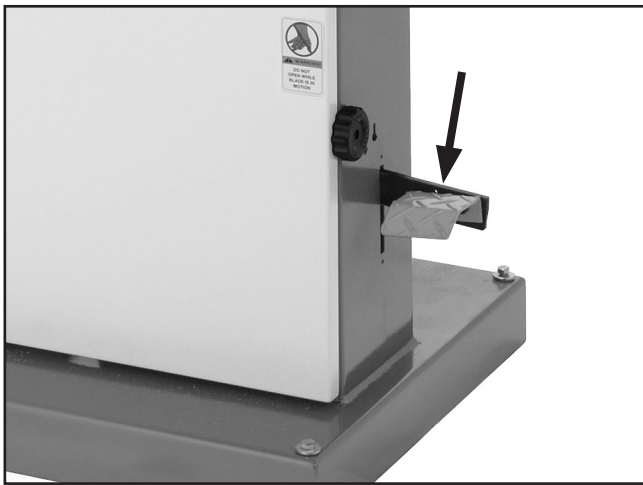


# Foot Brake

The Model G0636X is equipped with a foot brake (**Figure 38**). Use the brake only in emergency situations to stop power from going to the motor and bring the blade to a halt.

## **CAUTION**

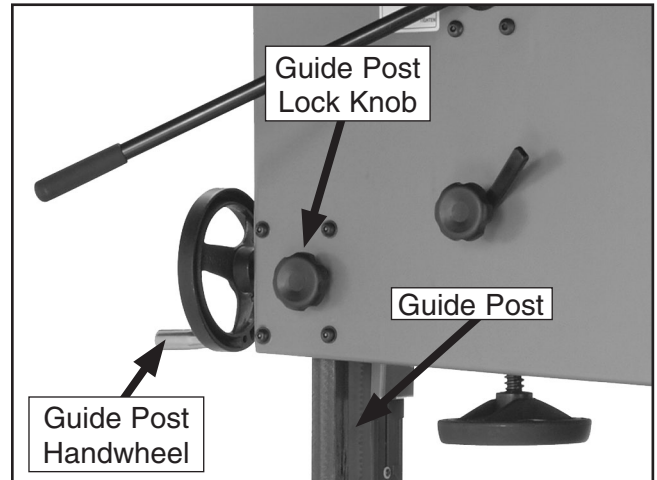
The foot brake will not stop the bandsaw wheels and blade instantly. **DO NOT** become over confident and relax your safety awareness because of the foot brake feature.



**Figure 38.** Foot brake location.

# Guide Post

The guide post, shown in **Figure 39**, connects the upper blade guide assembly to the bandsaw. The guide post allows the blade guide assembly to move up or down via a rack and pinion. In order to cut accurately, the blade guide assembly must be no more than 1" from the top of the workpiece at all times—this positioning provides the best support for the blade.



**Figure 39.** Guide post controls.

### To adjust guide post:

1. Make sure that the blade tension, blade tracking, support bearings, and blade guides are adjusted correctly.
2. Loosen the guide post lock knob shown in **Figure 39**.
3. Turn the guide post handwheel to raise or lower the guide post until the upper blade guide assembly is within 1" from the top of the workpiece.
4. Lock the guide post in place with the lock knob.



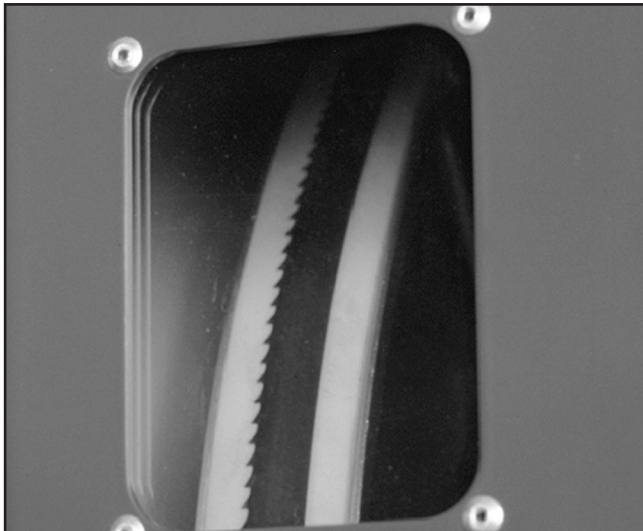
# Fine Tune Tracking

## **NOTICE**

Adjusting the final blade tracking setting requires the machine to be turned **ON**.

### To fine tune the tracking:

1. Close the wheel covers and turn the bandsaw **ON**.
2. Observe the blade tracking path through the clear window on the right edge of the bandsaw, as shown in **Figure 40**.

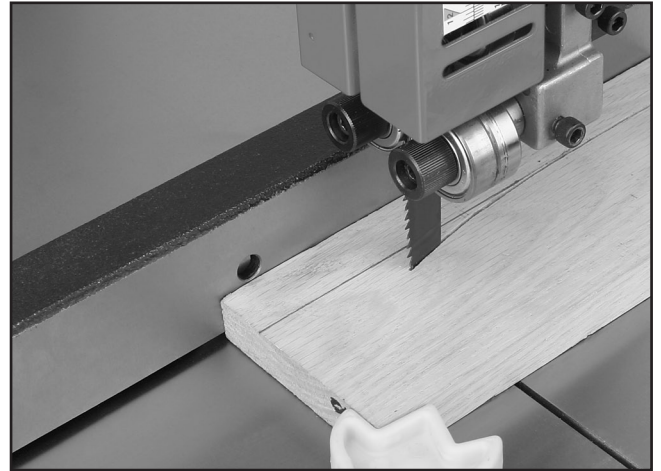


**Figure 40.** Blade tracking window.

3. Using the tracking controls (**Page 17, Figure 14**), adjust the blade so it tracks on the center of the wheel.
4. Tighten the lock lever so the tracking knob cannot move.

# Blade Lead

Bandsaw blades commonly wander off the cut line when sawing, as shown in **Figure 41**. This is called blade lead. Blade lead is commonly caused by too fast of a feed rate, a dull or abused blade, or improper tension. If your blade is sharp/undamaged and you still have blade lead, perform the following instructions.



**Figure 41.** Example of blade leading away from line of cut.

### To correct blade lead:

1. Use less pressure when feeding the workpiece through the cut.
2. Check that the miter slot or fence is parallel to the blade line, and correct if necessary (See **Aligning Table, Page 25** and **Aligning Fence, Page 26**).
3. Check for proper blade tension. If the blade tension is correct and it is not convenient to replace the blade, compensate for lead by skewing the fence or adjusting the table.

### To skew your fence:

1. Cut a piece of scrap wood approximately  $\frac{3}{4}$ " thick x 3" wide x 17" long. On a wide face of the board, draw a straight line parallel to the long edge.

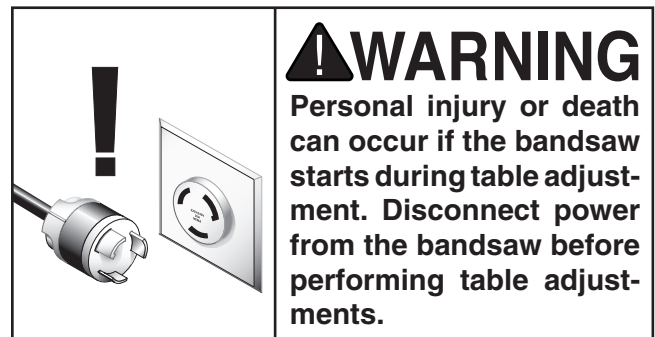


2. Slide the bandsaw fence out of the way and cut halfway through the board on the line by pushing it into the blade. Turn the bandsaw **OFF** and wait for the blade to stop.
3. Clamp the board to the bandsaw table without moving it. Now slide the fence over to the board so it barely touches one end of the board.
4. Loosen the two cap screws that secure the fence rail to the underside of the table (see **Page 26**).
5. Skew the fence so it is parallel to the edge of the scrap piece.
6. While maintaining the skew, tighten the cap screws loosened in **Step 4**.
7. Make a few cuts using the fence. If the fence still does not seem parallel to the blade, repeat **Steps 1–6** until the blade and fence are parallel with each other.

#### To shift the table:

1. On a scrap piece of wood, mark a line that is perpendicular to the front edge.
2. Cut halfway through the board on the line by pushing it into the blade.
3. Turn the bandsaw **OFF** and wait for the blade to stop.
4. Using an 8mm hex wrench, loosen the four cap screws that mount the table to the trunnion (**Figure 31**). Shift the table to compensate for the blade lead, then retighten the cap screws.
5. Repeat **Steps 1–4** until the blade cuts straight.

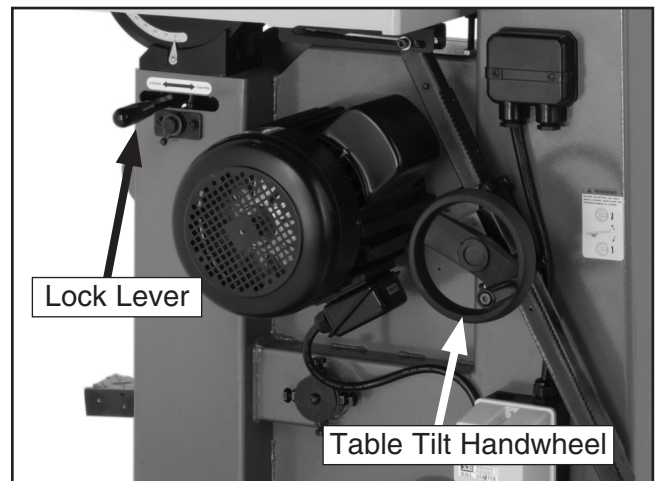
## Table Tilt



The bandsaw table will tilt 5° left and 45° right to provide a wide range of cutting options.

#### To tilt the table:

1. DISCONNECT BANDSAW FROM POWER!
2. Loosen the table tilt lock lever shown in **Figure 42**.



**Figure 42.** Table tilt controls.

3. To tilt the table to the right, turn the table tilt handwheel clockwise (**Figure 42**).
4. To tilt the table to the left, turn the table tilt handwheel clockwise one turn, lower the positive stop bolt, then turn the handwheel counterclockwise.
5. Secure the table tilt lock lever.
6. Follow "Positive Stop" instructions on **Page 17** for resetting the stop bolt and table for horizontal (0°) operations.





# Ripping

Ripping is the process of cutting with the grain of the wood stock. For plywood and other processed wood, ripping simply means cutting down the length of the workpiece. For ripping, a wider blade is better. In most ripping applications, a standard raker tooth style will be sufficient.

## To make a rip cut:

1. Adjust the fence to match the width of the cut on your workpiece and lock the fence in place.
2. Adjust the blade guide assembly to the correct height.
3. After all safety precautions have been met, turn the bandsaw **ON**. Slowly feed the workpiece into the blade and continue with the cut until the blade is completely through the workpiece. **Figure 43** shows a typical ripping operation. **Note:** *If you are cutting narrow pieces, use a push stick to protect your fingers.*



**Figure 43.** Example of typical ripping operation with a push stick.

## **!WARNING**

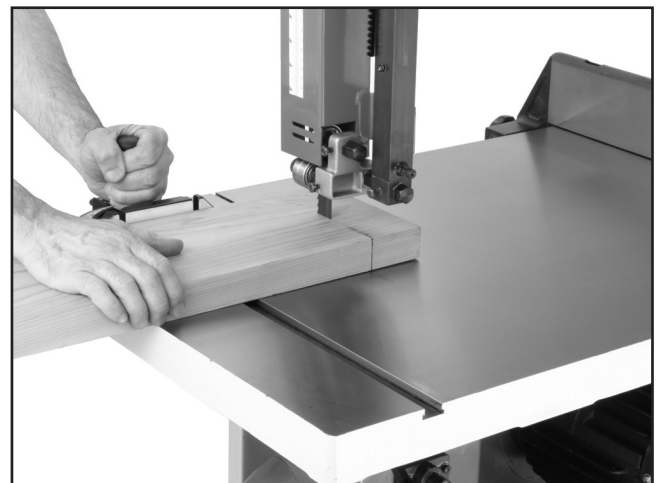
**NEVER** place fingers or hands in the line of cut. In the event that something unexpected happens, your hands or fingers may slip into the blade. **ALWAYS** use a push stick when ripping narrow pieces. Failure to follow these warnings may result in serious personal injury!

# Crosscutting

Crosscutting is the process of cutting across the grain of wood. For plywood and other processed wood, crosscutting simply means cutting across the width of the material.

## To make a 90° crosscut:

1. Mark the workpiece on the edge where you want to begin the cut.
2. Adjust the blade guide assembly to the correct height and make sure the miter gauge is set to 0°.
3. Move the fence out of the way. Place the workpiece evenly against the miter gauge.
4. Hold the workpiece against the miter gauge and line up the mark with the blade.
5. After all safety precautions have been met, turn the bandsaw **ON**. Slowly feed the workpiece into the blade and continue the cut until the blade is all the way through the workpiece. **Figure 44** shows a typical crosscutting operation.



**Figure 44.** Example of crosscutting operation with miter gauge.



# Resawing

Resawing (**Figure 45**) is the process of cutting a board into two or more thinner boards. The maximum board width that can be resawn is limited by the maximum cutting height of the bandsaw.

One of the most important considerations when resawing is blade selection. Generally, wider blades are better. In most applications, a hook or a skip tooth style will be desirable. Choose blades with fewer teeth-per-inch (from 3 to 6), because they offer larger gullet capacities for clearing sawdust, reducing heat buildup and reducing strain on the motor.



**Figure 45.** Example of resawing lumber.

## **⚠ WARNING**

**When resawing thin pieces, a wandering blade (blade lead) can tear through the surface of the workpiece, exposing your hands to the blade teeth. Always use push blocks when resawing and keep your hands clear of the blade.**

### To resaw a workpiece:

1. Verify that the bandsaw is setup properly and that the fence is parallel to the blade.
2. Adjust the upper blade guide so it is about 1" above the workpiece with a minimum amount of blade exposed.
3. Install the resaw fence, set it to the desired width of cut, and lock it in place.

## **NOTICE**

**The scale on the front rail will NOT be accurate when using the resaw fence.**

4. Support the ends of the board if necessary.
5. Turn the bandsaw **ON**.
6. Using push paddles and a push stick, keep pressure against the fence and table, and slowly feed the workpiece into the moving blade until the blade is completely through the workpiece (see **Figure 45**).

# Cutting Curves

When cutting curves, simultaneously feed and turn the stock carefully so that the blade follows the layout line without twisting. If a curve is so abrupt that it is necessary to repeatedly back up and cut a new kerf, use either a narrower blade or a blade with more TPI (teeth per inch), or make more relief cuts.

Always make short cuts first, then proceed to the longer cuts. Relief cuts will also reduce the chance that the blade will be pinched or twisted. Relief cuts are cuts made through the waste portion of the workpiece and are stopped at the layout line. As you cut along the layout line, waste wood is released from the workpiece, alleviating any pressure on the back of the blade. Relief cuts also make backing the workpiece out easier, if needed.

## **NOTICE**

**The list below displays blade widths and the corresponding minimum radii for those blade widths.**

Width	Radius
1/8" .....	1/8"
3/16" .....	3/8"
1/4" .....	5/8"
3/8" .....	1 1/4"
1/2" .....	2 1/2"
5/8" .....	3 3/4"
3/4" .....	5 1/2"

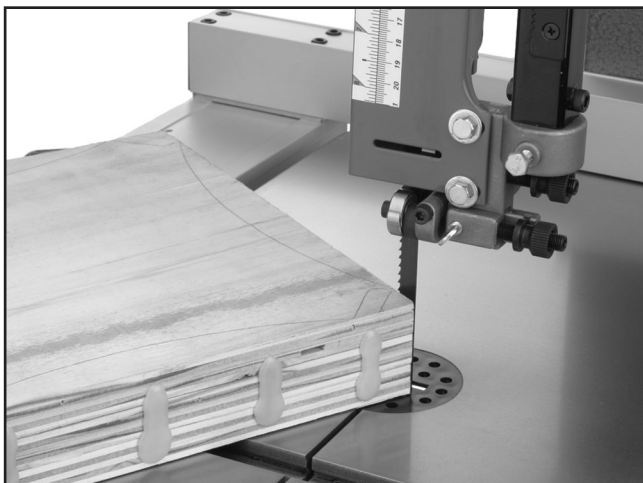


# Stacked Cuts

One of the benefits of a bandsaw is its ability to cut multiple copies of a particular shape by stacking a number of workpieces together. Before making stacked cuts, ensure that both the table and the blade are properly adjusted to 90° (see **Page 17**). Otherwise, any error will be compounded.

## To complete a stacked cut:

1. Align your pieces from top to bottom to ensure that each piece has adequate scrap to provide a clean, unhampered cut.
2. Secure all the pieces together in a manner that will not interfere with the cutting. Hot glue on the edges works well, as do brad nails through the waste portion. (Be careful not to cut into the brads or you may break the blade!)
3. On the face of the top piece, lay out the shape you intend to cut.
4. Make relief cuts perpendicular to the outline of your intended shape in areas where changes in blade direction could strain the woodgrain or cause the blade kerf to bind.
5. Cut the stack of pieces as though you were cutting a single piece. Follow your layout line with the blade kerf on the waste side of your line, as shown in **Figure 46**.



**Figure 46.** Typical stacked cut.

# Blade Information

Selecting the right blade requires a knowledge of the various blade characteristics to match the blade with the particular cutting operation.

## Blade Length

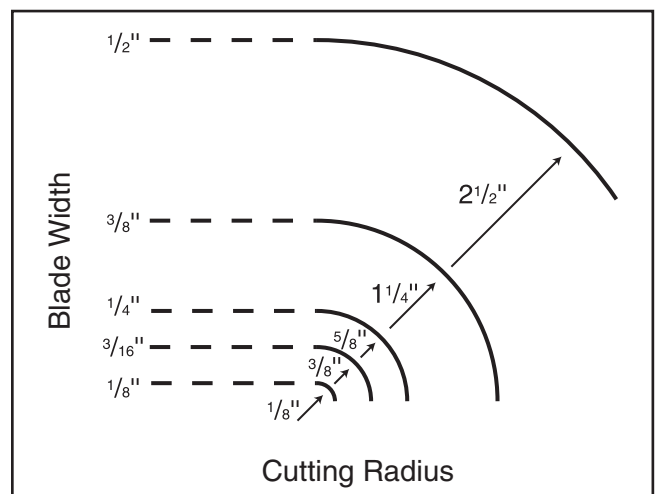
Measured by the circumference, blade lengths are usually unique to the brand of your bandsaw and the distance between wheels. The Model G0636X is designed for blades that are 160" long. Refer to **Page 37** for blade replacements.

## Blade Width

Measured from the back of the blade to the tip of the blade tooth (the widest point), blade width is often the first consideration given to blade selection. Blade width dictates the largest and smallest curve that can be cut, as well as how accurately it can cut a straight line.

The Model G0636X can use blades from 1/8" to 1 3/8" in width. Always pick the size of blade that best suits your application.

- **Curve Cutting:** Use the chart in **Figure 47** to determine the correct blade for curve cutting. Determine the smallest radius curve that will be cut on your workpiece and use the corresponding blade width.



**Figure 47.** Blade width radii.

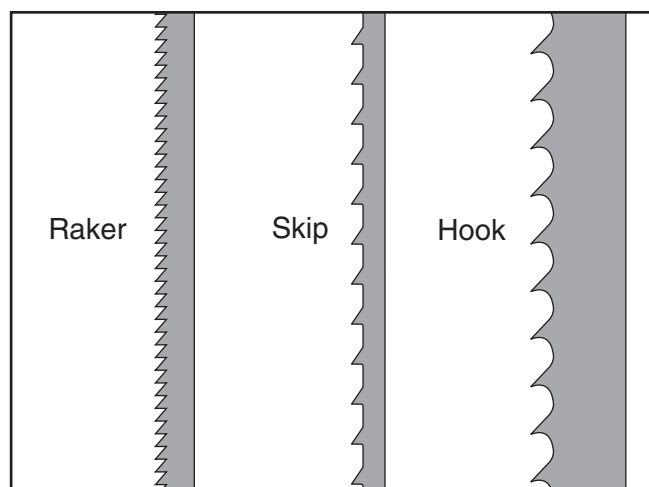




- **Straight Cutting:** Use the largest width blade that you own. Narrow blades can cut tight curves (a small radius) but are not very good at cutting straight lines because they naturally wander (blade lead). However, larger blades are much better at cutting straight lines, but function poorly at cutting small curves because of their size.

## Tooth Style

When selecting blades, another option to consider is the shape, gullet size, teeth set and teeth angle—otherwise known as “Tooth Style.” **Figure 48** shows the three main categories of tooth style:



**Figure 48.** Raker, Skip & Hook tooth styles.

- **Raker:** This style is considered to be the standard because the tooth size and shape are the same as the tooth gullet. The teeth on raker blades usually are very numerous, have no angle, and produce cuts by scraping the material; these characteristics result in very smooth cuts, but do not cut fast and generate more heat while cutting.
- **Skip:** This style is similar to a raker blade that is missing every other tooth. Because of the design, skip toothed blades have a much larger gullet than raker blades, and therefore, cut faster and generate more heat. However, these blades also leave a rougher cut than raker blades.

- **Hook:** The teeth on this style have a positive angle (downward) which makes them dig into the material, and the gullets are usually rounded for easier waste removal. These blades are excellent for the tough demands of resawing and ripping thick material.

## Tooth Pitch

Usually measured as TPI (teeth per inch), tooth pitch determines the size of the teeth. More teeth per inch (fine pitch) will cut slower, but smoother; while fewer teeth per inch (coarse pitch) will cut rougher, but faster. As a general rule, choose blades that will have at least three teeth in the material at all times. Use fine pitched blades on harder woods and coarse pitched blades on softer woods.

## Blade Care

A bandsaw blade is a delicate piece of steel that is subjected to tremendous strain. You can obtain longer use from a bandsaw blade if you give it fair treatment and always use the appropriate feed rate for your operation.

Be sure to select blades with the proper width, style, and pitch for each application. The wrong choice of blades will often produce unnecessary heat which will shorten the life of your blade.

A clean blade will perform much better than a dirty blade. Dirty or gummed up blades pass through the cutting material with much more resistance than clean blades. This extra resistance also causes unnecessary heat.

## Blade Breakage

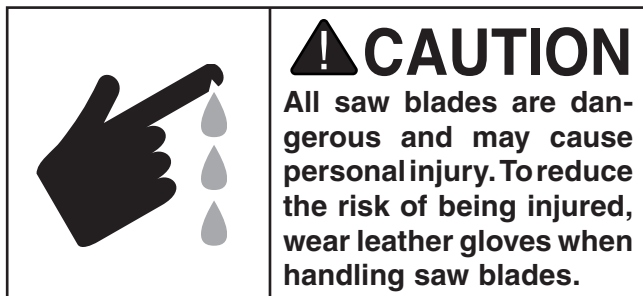
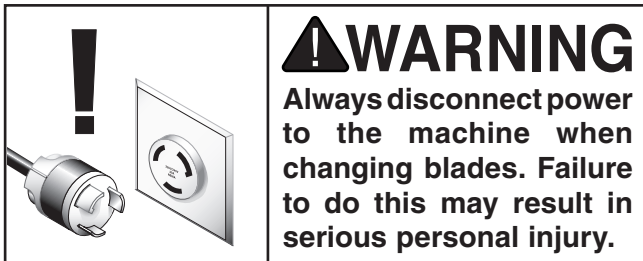
Many conditions may cause a bandsaw blade to break. Blade breakage is unavoidable, in some cases, since it is the natural result of the peculiar stresses that bandsaw blades are subjected to. Blade breakage is also due to avoidable circumstances. Avoidable breakage is most often the result of poor care or judgement on the part of the operator when mounting or adjusting the blade or support guides.



## The most common causes of blade breakage are:

- Faulty alignment and adjustment of the guides.
- Forcing or twisting a wide blade around a curve of short radius.
- Feeding the workpiece into the blade too fast.
- Tooth dullness or absence of sufficient set.
- Incorrect tension.
- Top blade guide assembly set too high above the workpiece.
- Using a blade with a lumpy or improperly finished braze or weld.
- Continuously running the bandsaw when not in use.

## Blade Changes



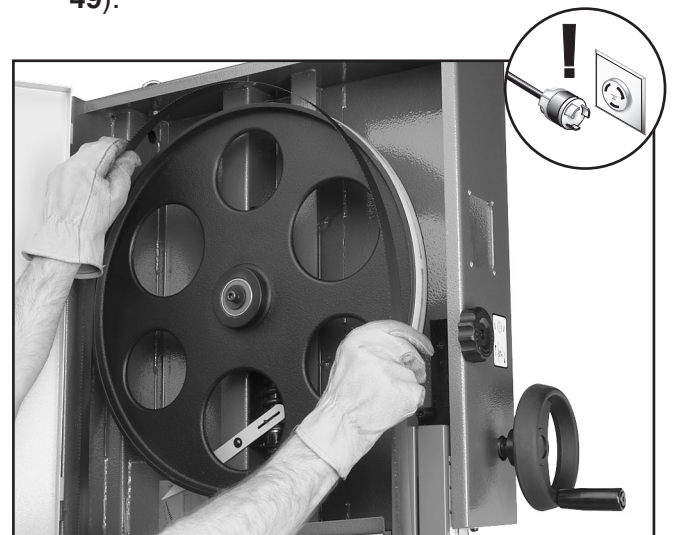
### To remove a blade:

1. DISCONNECT BANDSAW FROM POWER!
2. Release the blade tension.

3. Remove the table insert and the table pin. Adjust the upper and lower guide bearings as far away as possible from the blade.
4. Open the upper and lower wheel covers, and with gloved hands, slide the blade off of both wheels.
5. Slide the blade through the slot in the table.

### To replace a blade:

1. Slide the blade through the table slot, ensuring that the teeth are pointing forward and down toward the table. **Note:** *If the teeth will not point downward in any orientation, the blade is inside-out. Put on heavy gloves, remove the blade, and twist it right side-out.*
2. Slip the blade through the guides, and mount it on the upper and lower wheels (**Figure 49**).



**Figure 49.** Typical example of placing blade on the wheels.

3. Adjust tension as described on **Page 21**.
4. Adjust tracking if needed (see **Page 16**).
5. Adjust the upper/lower guide bearings and the support bearings (see **Page 21**).
6. Replace the table insert and table pin.
7. Close the wheel covers.



# SECTION 5: ACCESSORIES

## Replacement Blades

These replacement blades are milled for exact tooth set and are made with high quality tool steel.

### 160" Carbon Steel Replacement Blades for the Model G0636X.

MODEL	WIDTH	TPI
H8416	3/8"	6 HOOK
H8417	3/8"	10 RAKER
H8418	1/2"	4 HOOK
H8419	1/2"	6 HOOK
H8420	3/4"	3 HOOK
H8421	1"	6 HOOK
H8422	1"	2 HOOK

### 160" Timber Wolf® Replacement Blades for the Model G0636X.

MODEL	WIDTH	TPI
H8423	1/2"	3 POS. CLAW
H8424	1/2"	4 POS. CLAW
H8425	1/2"	6 POS. CLAW
H8426	1/2"	10 RAKER
H8427	1"	3 POS. CLAW
H8428	1"	4 POS. CLAW
H8429	1"	10 RAKER
H8430	1 1/4"	3/4" PITCH

### G1094—Bandsaw Power Feeder with Fence, Single-Phase



Figure 50. G1094 Bandsaw Power Feeder.

### 162" Carbon Steel Replacement Blades for the Model G0636X.

MODEL	WIDTH	TPI
H4819	3/8"	6 HOOK
H4820	3/8"	10 RAKER
H4821	1/2"	4 HOOK
H4822	1/2"	6 HOOK
H4823	3/4"	3 HOOK
H4824	1"	6 HOOK
H4825	1"	2 HOOK

### 162" Timber Wolf® Replacement Blades for the Model G0636X.

MODEL	WIDTH	TPI
H9567	1/2"	3 POS. CLAW
H9568	1/2"	4 POS. CLAW
H9569	1/2"	6 POS. CLAW
H9570	1/2"	10 RAKER
H9571	1"	3 POS. CLAW
H9572	1"	4 POS. CLAW
H9573	1"	10 RAKER
H9574	1 1/4"	3/4" PITCH

### G7315—Super Heavy-Duty SHOP FOX® Mobile Base

This patented, super heavy-duty mobile machine base is the strongest mobile base on the market. 18" x 24 1/2" minimum and adjusts to 28 1/2" x 33 1/2" maximum 1300 lb. capacity. This base is extremely stable with outrigger type supports and a four wheel system. Weighs 61 lbs.

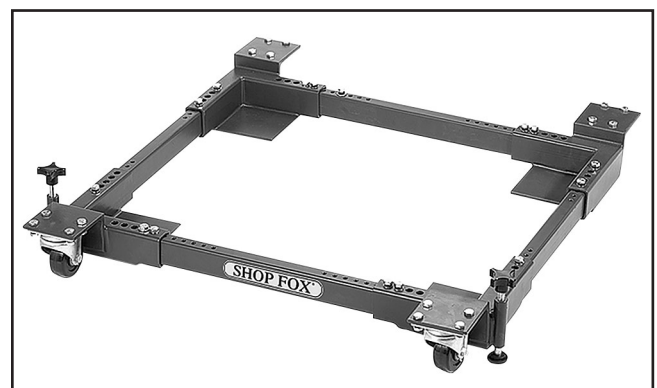


Figure 51. G7315 SHOP FOX® Mobile Base.

Call 1-800-523-4777 To Order



- H2347—Uvex® Spitfire Safety Glasses**
- H1300—UV Blocking, Clear Safety Glasses**
- G7984—Face Shield**
- H1298—Dust Sealed Safety Glasses**
- H0736—Shop Fox® Safety Glasses**

Safety Glasses are essential to every shop. If you already have a pair, buy extras for visitors or employees. You can't be too careful when it comes to shop safety!



**Figure 53.** Our most popular safety glasses.

- H1302—Standard Earmuffs**
  - H4979—Deluxe Twin Cup Hearing Protector**
  - H4977—Work-Tunes Radio Headset Earmuffs**
- Protect yourself comfortably with a pair of cushioned earmuffs. Especially important if you or employees operate for hours at a time.



**Figure 54.** Our most popular earmuffs.

- H2499—Small Half-Mask Respirator**
- H3631—Medium Half-Mask Respirator**
- H3632—Large Half-Mask Respirator**
- H3635—Disposable Cartridge Filter Pair P100**

Wood dust is now considered a known carcinogen and has been linked to nasal cancer and severe respiratory illnesses. If you work around dust everyday, a half-mask respirator can be a lifesaver. Also compatible with safety glasses!



**Figure 55.** Half-mask respirator and disposable cartridge filters.

- G5562—SLIPIT® 1 Qt. Gel**
- G5563—SLIPIT® 12 oz Spray**
- G2871—Boeshield® T-9 12 oz Spray**
- G2870—Boeshield® T-9 4 oz Spray**
- H3788—G96® Gun Treatment 12 oz Spray**
- H3789—G96® Gun Treatment 4.5 oz Spray**



**Figure 56.** Recommended products for protecting unpainted cast iron/steel on machinery.

**Call 1-800-523-4777 To Order**



# SECTION 6: MAINTENANCE

---

---



## Schedule

---

---

For optimum performance from your machine, follow this maintenance schedule and refer to any specific instructions given in this section.

### Daily Check:

- Loose mounting bolts.
- Damaged saw blade.
- Worn or damaged wires.
- Any other unsafe condition.

### Monthly Check:

- V-belt tension, damage, or wear.
- Clean/vacuum dust buildup from inside cabinet and off motor.

## Cleaning

---

---

Cleaning the Model G0636X is relatively easy. Vacuum excess wood chips and sawdust, and wipe off the remaining dust with a dry cloth. If any resin has built up, use a resin dissolving cleaner to remove it. Treat all unpainted cast iron and steel with a non-staining lubricant after cleaning.

## Unpainted Cast Iron

---

---

Protect the unpainted cast iron surfaces on the table by wiping the table clean after every use—this ensures moisture from wood dust does not remain on bare metal surfaces.

Keep tables rust-free with regular applications of products like G96® Gun Treatment, SLIPIT®, or Boeshield® T-9 (see **Section 5: Accessories** on **Page 37** for more details).

## Brushes

---

---

The bandsaw is equipped with three lower brushes. The brushes should be checked daily and cleaned when they become dirty. There are adjustment brackets that allow the brushes to be adjusted for bristle wear. Refer to **Adjusting Brushes** on **Page 46** for adjustment details.

## Lubrication

---

---

Sealed and pre-lubricated ball bearings require no lubrication for the life of the bearings. All bearings are standard sizes, and replacements can be purchased from our parts department or a bearing supply store.

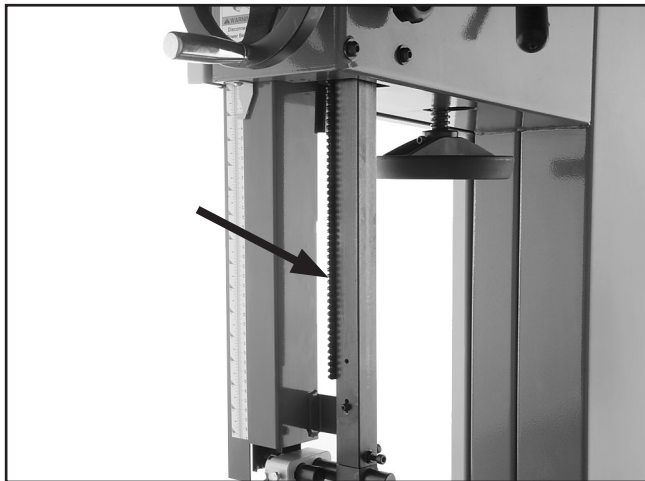
Most other moving parts need to be lubricated as needed to maintain smooth function of the bandsaw.





### To lubricate the blade guide rack and pinion:

1. DISCONNECT BANDSAW FROM POWER!
2. Lower the blade guide until it reaches the table.
3. Wipe off any existing grease and sawdust buildup on the rack (**Figure 57**)



**Figure 57.** Rack lubrication location.

4. Apply a thin coat of light all-purpose grease to the rack.
5. Move the blade guide up and down several times and remove any excess grease to help prevent sawdust buildup.

### To lubricate the blade tracking knob:

1. DISCONNECT BANDSAW FROM POWER!
2. Unscrew the blade tracking knob 5 turns.
3. Wipe off any existing grease and sawdust buildup on the threads.
4. Apply a few dabs of a light all-purpose grease to the threads.
5. Re-adjust tracking (see **Blade Tracking** on **Page 16**).

### To lubricate the tension adjustment assembly:

1. DISCONNECT BANDSAW FROM POWER!
2. Open the top wheel cover and look through the top of the wheel.
3. Wipe off any existing grease and sawdust buildup on the blade tension adjustment assembly and tension lever cam.
4. Apply a thin coat of grease to the tension adjustment assembly and tension lever cam (**Figure 58**).

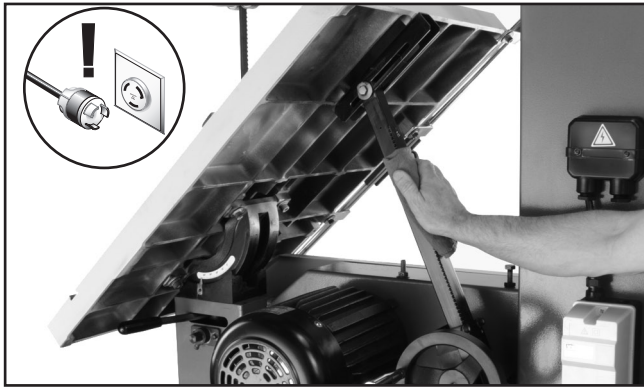


**Figure 58.** Tension adjustment assembly locations (top wheel removed for clarity).



**To lubricate the table tilt rack and pinion assembly:**

1. DISCONNECT BANDSAW FROM POWER!
2. With the table perpendicular to the blade, wipe off all existing grease and sawdust buildup from the rack.
3. Move the table up to its maximum 45° angle and wipe (**Figure 59**) off all existing grease and sawdust buildup from the rack.

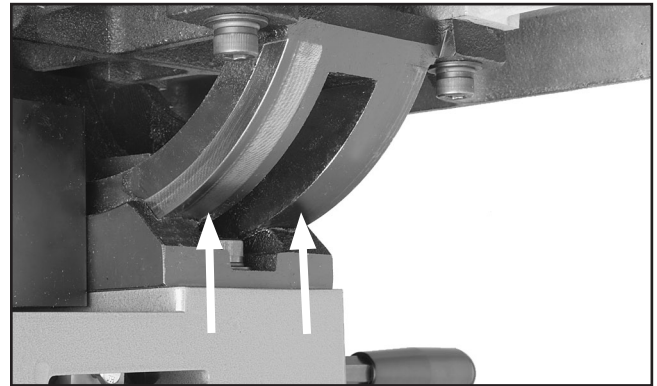


**Figure 59.** Table tilt rack and pinion assembly.

4. Apply a thin coat of light all-purpose grease to the rack.
5. Move the table up and down several times to distribute the grease, then wipe off any excess grease.

**To lubricate the trunnions:**

1. DISCONNECT BANDSAW FROM POWER!
2. Move the table up until it reaches its maximum 45° angle and wipe off all excess grease and sawdust from the trunnions.
3. Apply a thin coat of light all purpose grease to the trunnions (**Figure 60**).



**Figure 60.** Trunnion lubrication location.

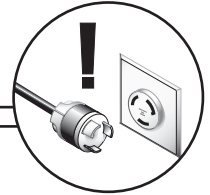
4. Move the table down and then back up to distribute the grease, then wipe off any excess grease from the trunnions.



# SECTION 7: SERVICE

Review the troubleshooting and procedures in this section to fix or adjust your machine if a problem develops. If you need replacement parts or you are unsure of your repair skills, then feel free to call our Technical Support at (570) 546-9663.

## Troubleshooting



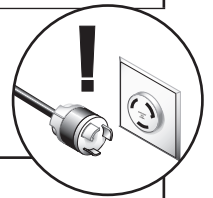
### Motor & Electrical

Symptom	Possible Cause	Possible Solution
Machine does not start or a breaker trips.	<ol style="list-style-type: none"> <li>1. Key is turned to "0".</li> <li>2. Stop/reset button engaged.</li> <li>3. Plug/receptacle is at fault or wired incorrectly.</li> <li>4. Motor connection wired incorrectly.</li> <li>5. Thermal protection circuit breaker amperage is set too low or motor is at fault.</li> <li>6. Power supply is at fault/switched OFF.</li> <li>7. Motor ON/OFF switch is at fault.</li> <li>8. Wiring is open/has high resistance.</li> <li>9. Start capacitor is at fault.</li> <li>10. Motor is at fault.</li> <li>11. Wheel cover limit switch is not closed, wheel covers are open.</li> <li>12. Foot brake limit switch is at fault or is pressed down (switch is not closed).</li> </ol>	<ol style="list-style-type: none"> <li>1. Turn key to "1".</li> <li>2. Rotate clockwise until it pops out/replace.</li> <li>3. Test for good contact or correct the wiring.</li> <li>4. Correct motor wiring connections (<b>Page 50</b>).</li> <li>5. Unplug machine, open magnetic switch cover, turn amperage dial on Thermal Protection Circuit Breaker to a higher amperage setting. If switch is maxed out, replace motor.</li> <li>6. Ensure hot lines have correct voltage on all legs and main power supply is switched <b>ON</b>.</li> <li>7. Replace faulty ON/OFF switch.</li> <li>8. Check for broken wires or corroded/disconnected connections, and repair/replace as necessary.</li> <li>9. Test/replace if faulty.</li> <li>10. Repair/replace.</li> <li>11. Close wheel covers.</li> <li>12. Repair/replace limit switch, or stop pressing foot brake.</li> </ol>
Machine stalls or is underpowered.	<ol style="list-style-type: none"> <li>1. Motor run capacitor at fault.</li> <li>2. Wrong workpiece material.</li> <li>3. Feed speed too fast for task.</li> <li>4. V-belt slipping.</li> <li>5. Blade is slipping on wheels.</li> <li>6. Low power supply voltage.</li> <li>7. Plug/receptacle is at fault.</li> <li>8. Motor connection is wired incorrectly.</li> <li>9. Motor bearings are at fault.</li> <li>10. Motor has overheated.</li> <li>11. Motor is at fault.</li> </ol>	<ol style="list-style-type: none"> <li>1. Replace run capacitor.</li> <li>2. Use wood with correct moisture content, without glues, and little pitch/resins.</li> <li>3. Decrease feed speed. See <b>Basic Cutting Tips on Page 28</b>.</li> <li>4. Replace bad V-belt, align pulleys, and re-tension (<b>Page 44 &amp; 45</b>).</li> <li>5. Adjust blade tracking and tension to factory specifications. See <b>Page 16 or 21</b>.</li> <li>6. Ensure all hot lines have correct voltage on all legs.</li> <li>7. Test for good contacts and correct wiring.</li> <li>8. Correct motor wiring connections (<b>Page 50</b>).</li> <li>9. Test by rotating shaft; rotational grinding/loose shaft requires bearing replacement.</li> <li>10. Let motor cool, clean it off, and reduce workload.</li> <li>11. Repair/replace.</li> </ol>



Symptom	Possible Cause	Possible Solution
Machine has vibration or noisy operation when running.	<ol style="list-style-type: none"> <li>1. Blade weld hits guides or teeth are broken.</li> <li>2. Bent or worn out blade.</li> <li>3. Motor or component is loose.</li> <li>4. V-belt worn or loose.</li> <li>5. Motor fan is rubbing on fan cover.</li> <li>6. Pulley is loose.</li> <li>7. Machine is incorrectly mounted or sits unevenly on floor.</li> <li>8. Motor bearings are at fault.</li> <li>9. Worn arbor bearings.</li> <li>10. Wheels not coplanar/aligned correctly.</li> <li>11. Wheels out of balance.</li> </ol>	<ol style="list-style-type: none"> <li>1. Replace blade (<b>Page 36</b>).</li> <li>2. Replace blade (<b>Page 36</b>).</li> <li>3. Inspect/replace stripped or damaged bolts/nuts, and re-tighten with thread locking fluid.</li> <li>4. Inspect/replace belts with matched set (<b>Page 45</b>).</li> <li>5. Replace dented fan cover and loose/damaged fan.</li> <li>6. Realign/replace shaft, pulley, setscrew, and key as required.</li> <li>7. Adjust the feet on the bottom of the stand; relocate machine.</li> <li>8. Test by rotating shaft—rotational grinding/loose shaft requires bearing replacement.</li> <li>9. Check/replace arbor bearings.</li> <li>10. Adjust wheel alignment to coplaner (<b>Page 46</b>).</li> <li>11. Replace wheels.</li> </ol>

## Cutting Operations



Symptom	Possible Cause	Possible Solution
Machine slows when operating.	<ol style="list-style-type: none"> <li>1. Feeding workpiece too fast.</li> <li>2. Blade is dull.</li> </ol>	<ol style="list-style-type: none"> <li>1. Reduce feed rate. See <b>Basic Cutting Tips</b> on <b>Page 28</b>.</li> <li>2. Replace blade (<b>Page 36</b>).</li> </ol>
Ticking sound when the saw is running.	<ol style="list-style-type: none"> <li>1. Blade weld contacting support bearing.</li> <li>2. Blade weld may be failing.</li> </ol>	<ol style="list-style-type: none"> <li>1. Use file or stone to smooth and round the back of the blade.</li> <li>2. Inspect and replace blade if necessary (<b>Page 36</b>).</li> </ol>
Blade contacting table insert.	<ol style="list-style-type: none"> <li>1. Excessive side pressure when cutting.</li> <li>2. Table improperly adjusted.</li> </ol>	<ol style="list-style-type: none"> <li>1. Reduce side pressure.</li> <li>2. Adjust table (<b>Page 25</b>).</li> </ol>
Vibration when cutting.	<ol style="list-style-type: none"> <li>1. Loose or damaged blade.</li> <li>2. Blade is tracking incorrectly.</li> <li>3. Blade tension is loose.</li> </ol>	<ol style="list-style-type: none"> <li>1. Tighten or replace blade. See <b>Page 36 or 21</b>.</li> <li>2. Fix blade tracking (<b>Page 16</b>).</li> <li>3. Fix blade tension (<b>Page 21</b>).</li> </ol>
Burn marks on the edge of the cut.	<ol style="list-style-type: none"> <li>1. Too much side pressure when feeding workpiece.</li> <li>2. Blade too wide for size of radius being cut.</li> </ol>	<ol style="list-style-type: none"> <li>1. Feed workpiece straight into the blade. See <b>Basic Cutting Tips</b> on <b>Page 28</b>.</li> <li>2. Install a smaller width blade/increase blade tension. See <b>Page 21 or 36</b>.</li> </ol>
Rough or poor quality cuts.	<ol style="list-style-type: none"> <li>1. Feeding workpiece too fast.</li> <li>2. Tracking and tension incorrect.</li> </ol>	<ol style="list-style-type: none"> <li>1. Reduce feed rate. See <b>Basic Cutting Tips</b> on <b>Page 28</b>.</li> <li>2. Fix tracking and tension (see <b>Page 16 and 21</b>).</li> </ol>
Sawdust buildup inside cabinet.	<ol style="list-style-type: none"> <li>1. Clogged dust port.</li> <li>2. Low CFM (airflow) from dust collection system.</li> </ol>	<ol style="list-style-type: none"> <li>1. Clean out dust port.</li> <li>2. Three options: <ul style="list-style-type: none"> <li>—Check dust lines for leaks or clogs.</li> <li>—Move dust collector closer to saw.</li> <li>—Install a stronger dust collector.</li> </ul> </li> </ol>
Blade wanders or won't follow line of cut.	<ol style="list-style-type: none"> <li>1. Blade lead.</li> </ol>	<ol style="list-style-type: none"> <li>1. Refer to Blade Lead on <b>Page 30</b>.</li> </ol>



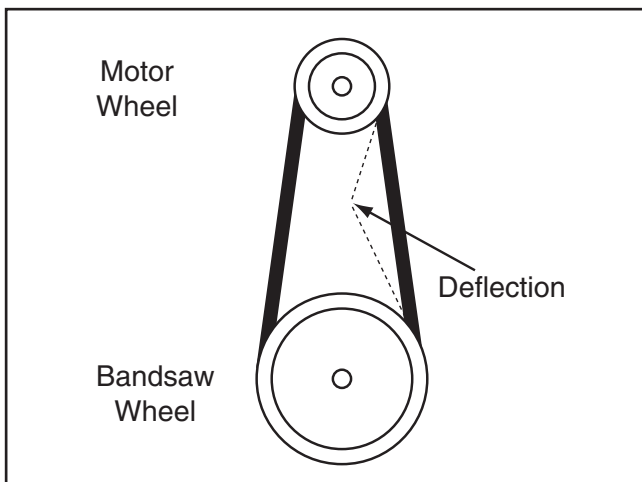
# Checking and Tensioning V-Belts

To ensure optimum power transmission from the motor to the blade, the V-belts must be in good condition and operate under proper tension. The belts should be checked for cracks, fraying, and wear. Belt tension should be checked at least every 3 months—more often if the bandsaw is used daily.

Tools Needed:	Qty
Ruler .....	1
Hex Wrench 6mm.....	1
Wrench 17mm .....	1

## To check the V-belts:

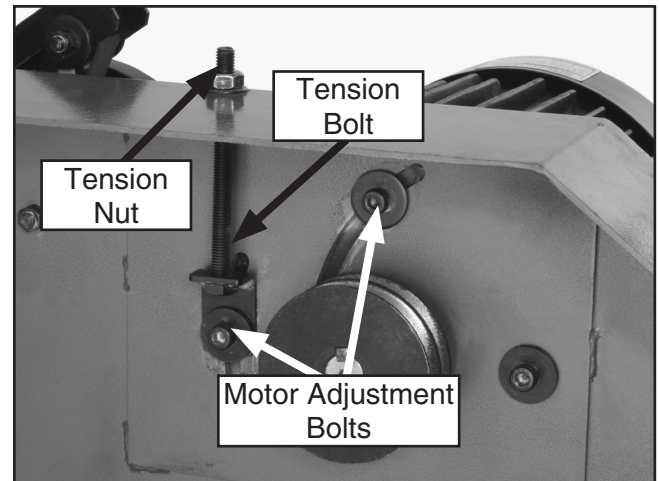
1. DISCONNECT BANDSAW FROM POWER!
2. Open the wheel covers.
3. Note the condition of the V-belts. If the V-belts are cracked, frayed, or glazed; they should be replaced.
4. Push the center of the V-belts. Note the amount of deflection (**Figure 61**). If deflection is more than  $\frac{3}{4}$ ", tension the V-belt.



**Figure 61.** V-belt deflection.

## To tension the V-belt:

1. DISCONNECT BANDSAW FROM POWER!
2. Open the wheel covers.
3. Loosen the motor adjustment bolts shown in **Figure 62**.



**Figure 62.** Motor mount bolts and tension bolt.

4. Adjust the belt tension:
  - If the belt is too loose, turn the tension nut clockwise to tighten the belts.
  - If the belt is too tight, turn the tension nut counterclockwise to loosen the belts
5. Push the center of the V-belt. If deflection is approximately  $\frac{3}{4}$ " with moderate pressure, then the tension is correct. If the deflection is more than  $\frac{3}{4}$ ", repeat **Step 4**.
6. When the V-belt tension is correct, tighten the motor adjustment bolts, and close the wheel covers.



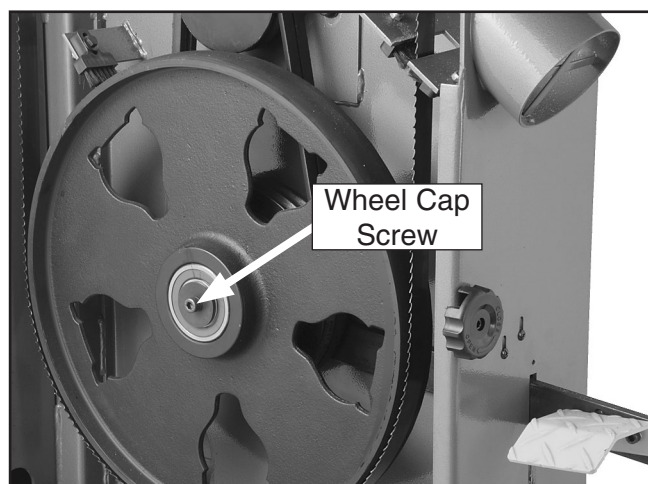


# Replacing V-Belts

Tools Needed:	Qty
Hex Wrench 6mm.....	1
Wrench 13mm.....	1

## To replace the V-belts:

1. DISCONNECT BANDSAW FROM POWER!
2. Open the wheel covers and remove the bandsaw blade (see **Page 36**).
3. Loosen the motor adjustment bolts and tension nut shown in **Figure 62**, then turn the tension bolt counterclockwise.
4. Unthread the wheel cap screw shown in **Figure 63** and slide the lower wheel off of the bearing shaft.



**Figure 63.** Wheel cap screw for removing the wheel.

5. Slip the old V-belts off of the pulleys and install the new V-belt set in their place.
6. Install the lower wheel back onto the bearing shaft, tighten the wheel mount cap screw, and tension the V-belt (see **Page 44**).
7. Close the lower wheel cover.

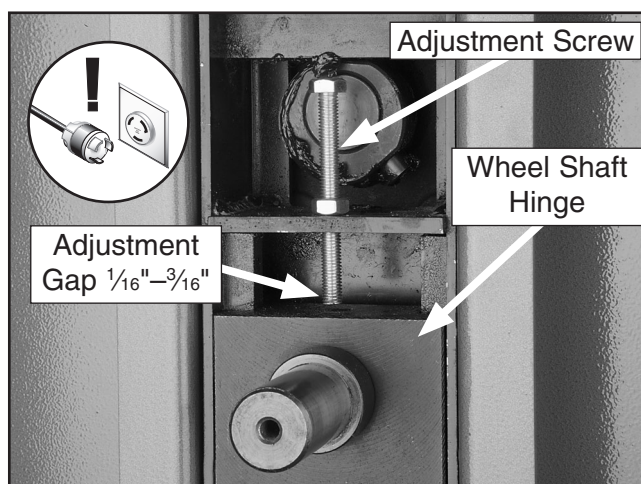
# Adjusting Tension Lever

The tension lever has an adjustment screw that allows you to adjust how much tension is released when the lever is used.

Tools Needed:	Qty
Wrench 13mm.....	1

## To adjust the tension lever:

1. DISCONNECT BANDSAW FROM POWER!
2. Loosen the adjustment screw 5–10 turns.
3. Move the tension lever to the tightened position and tension the blade.
4. Turn the adjustment screw shown in **Figure 64** until the gap between the screw and the wheel shaft hinge is  $\frac{1}{16}$ "– $\frac{3}{16}$ ".



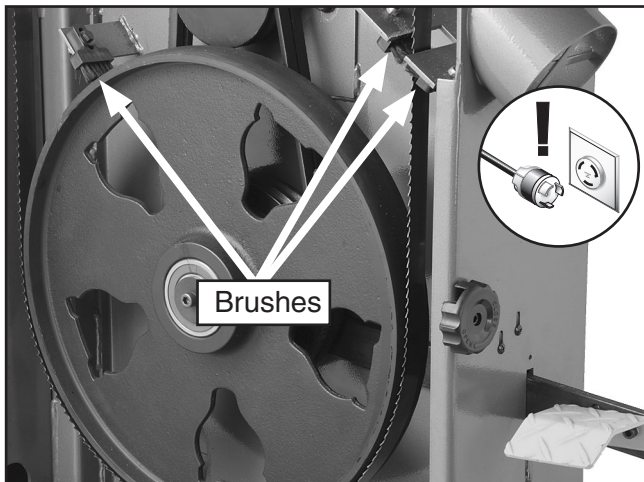
**Figure 64.** Tension lever adjustment components (top wheel removed for clarity).

5. Engage the the tension lever and test the blade tension.
6. Repeat **Steps 1–5** until the tension lever adds the right amount of tension to the blade when it is engaged.



# Adjusting Wheel and Blade Brushes

The lower wheel compartment contains the brushes shown in **Figure 65**. These brushes are designed to sweep sawdust off the wheel tire and blade as the bandsaw is operating. In order to work properly, the brushes must be making contact with the wheel and blade.



**Figure 65.** The wheel brush.

**Tools Needed:** Qty  
Wrench/Socket 10mm.....2

### To adjust the brushes:

1. DISCONNECT BANDSAW FROM POWER!
2. Open the lower wheel cover.
3. Loosen the bolt/nut that secures each brush in place.
4. Adjust each brush so it makes good contact with the wheel or blade—without bending the bristles.
5. Tighten the bolt/nuts to secure each brush in place.

# Wheel Alignment

**Components and Hardware Needed:** Qty  
70" Long Wood 2x4..... 1

### Tools Needed:

Wrench 17mm..... 1  
Tape Measure ..... 1  
Coplanarity Gauge (see **Figure 66**)..... 1

Wheel alignment is one of the most critical factors for optimal performance from your bandsaw.

Heat, vibration, wandering, blade wear, tire wear and overall bandsaw wear are considerably decreased when the wheels are properly aligned or “coplanar.”

Coplanar wheels automatically track the blade by balancing it on the crown of the wheel. This is known as coplanar tracking.

### To check if your wheels are coplanar (Checking coplanarity):

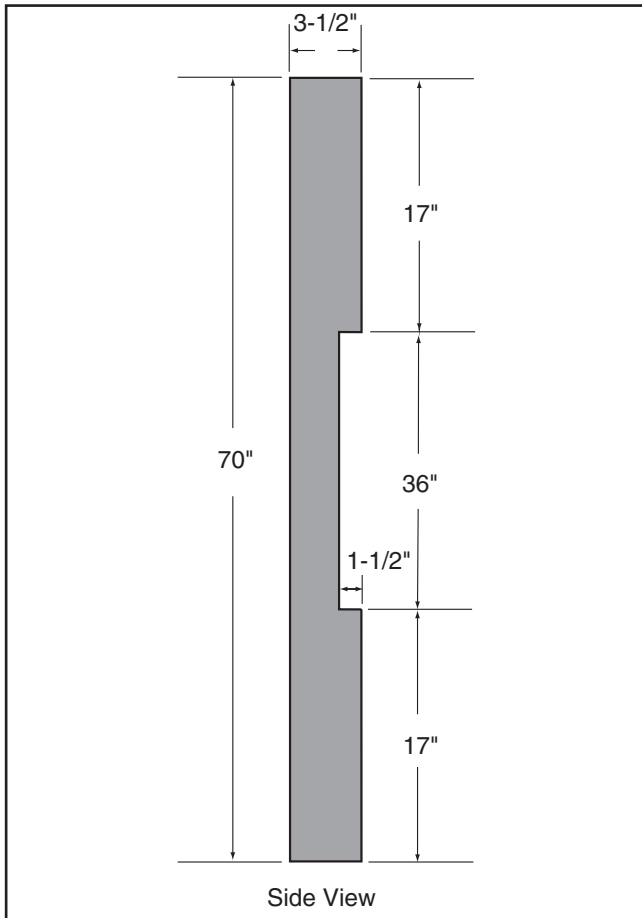
1. Make the "Coplanarity Gauge" shown in **Figure 66** on **Page 47**.

**Note:** For best results, straighten the 2x4 with a jointer before cutting.

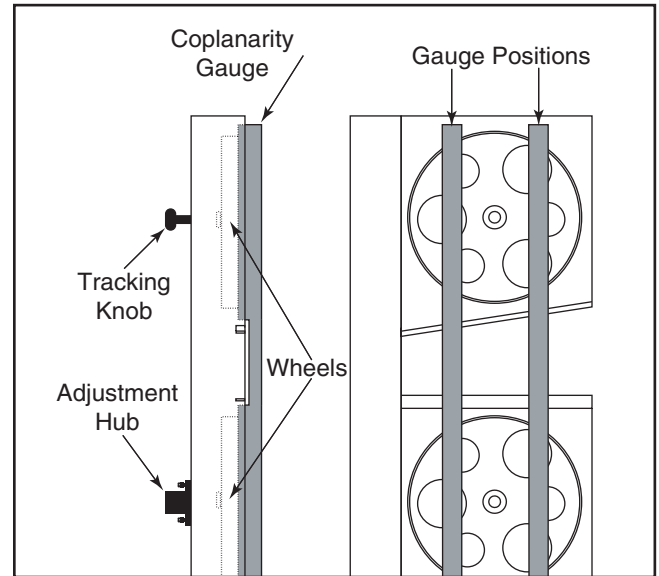
2. Remove the fence and open both wheel covers.
3. Adjust the blade guides away from the blade, loosen blade tension, remove the table insert and pin, and remove the blade.
4. Remove the four trunnion cap screws and the table.
5. Reinstall the blade (**Page 36**), making sure the guide bearings and support bearings are away from the blade, then tighten your blade to the tension that it will be used during operation.



- Place your coplanarity gauge up against both wheels in the positions shown in **Figure 67**.

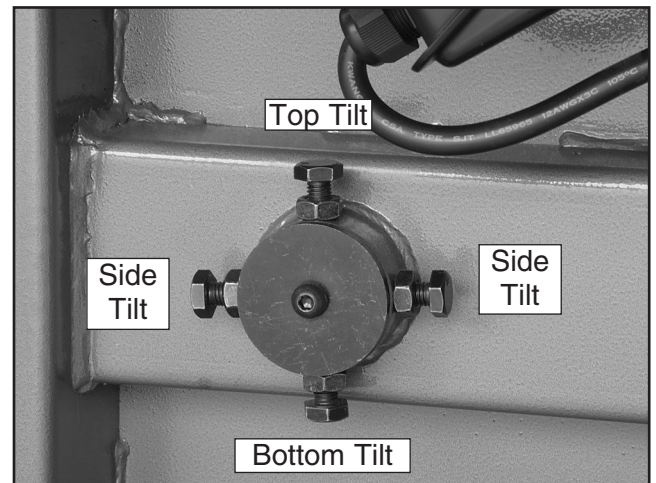


**Figure 66.** Dimensions of coplanarity gauge.



**Figure 67.** Checking for coplanarity.

- Adjust the tracking knob to get both wheels parallel. If the wheels won't go parallel to each other, then move the lower wheel at the adjustment hub (**Figure 68**) so they line up.



**Figure 68.** Lower wheel adjustment control.

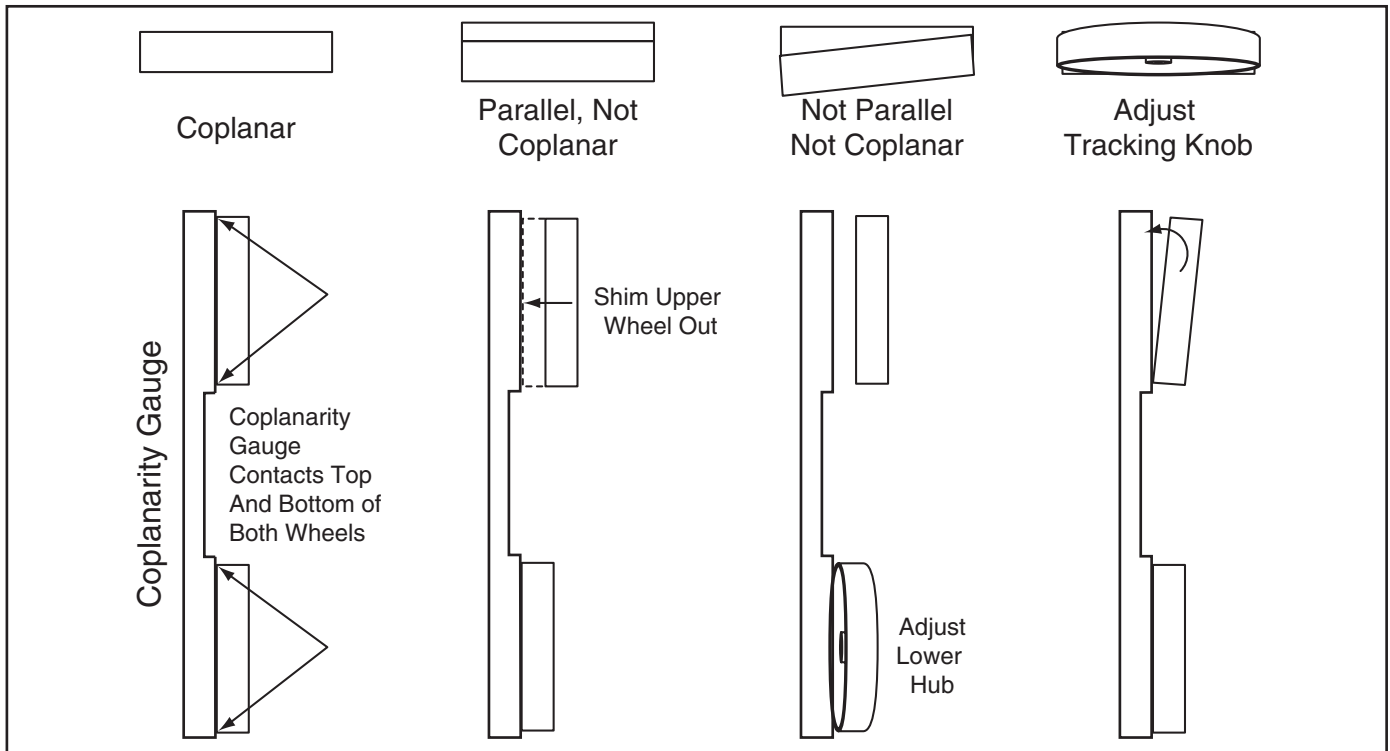
- If the wheels will go parallel but not coplanar, shim the upper wheel out as needed using thin  $\frac{3}{4}$ " washers on the shaft behind the wheel.



9. **Figure 69** shows the positions of the wheels when coplanar. When your wheels are coplanar, reinstall the table, table insert, and pin, readjust the guide blocks and rear support bearings, and close the wheel covers.

**Note:** *The blade may track slightly off-center when the wheels are coplanar. This is natural because the blade will be balanced on the crown of the tire, rather than just in the center of the tire. This will be more noticeable with larger blades.*

10. Finally, check table and fence alignment (see **Pages 25 & 26**).



**Figure 69.** Coplanarity diagram.





# Electrical Components

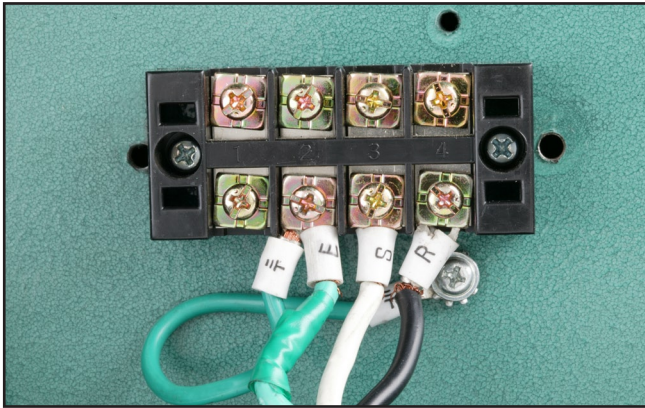


Figure 70. Power supply terminal box.

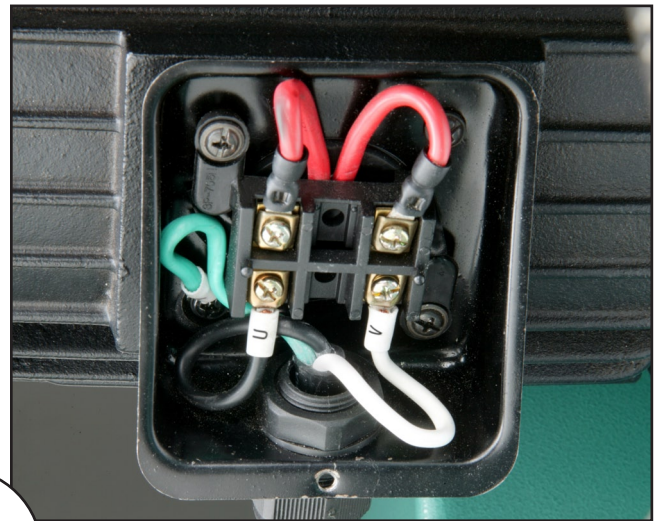


Figure 73. Motor wiring.

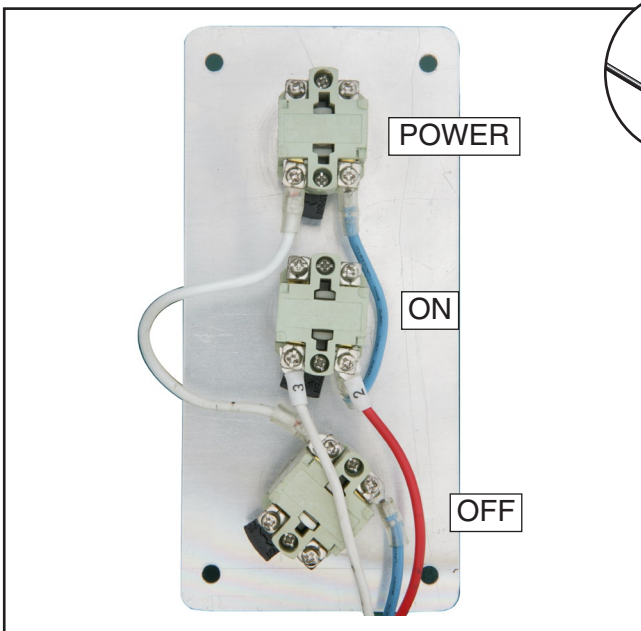


Figure 71. Control panel wiring.



Figure 72. Wheel cover limit switch (left) and foot brake switch (right).

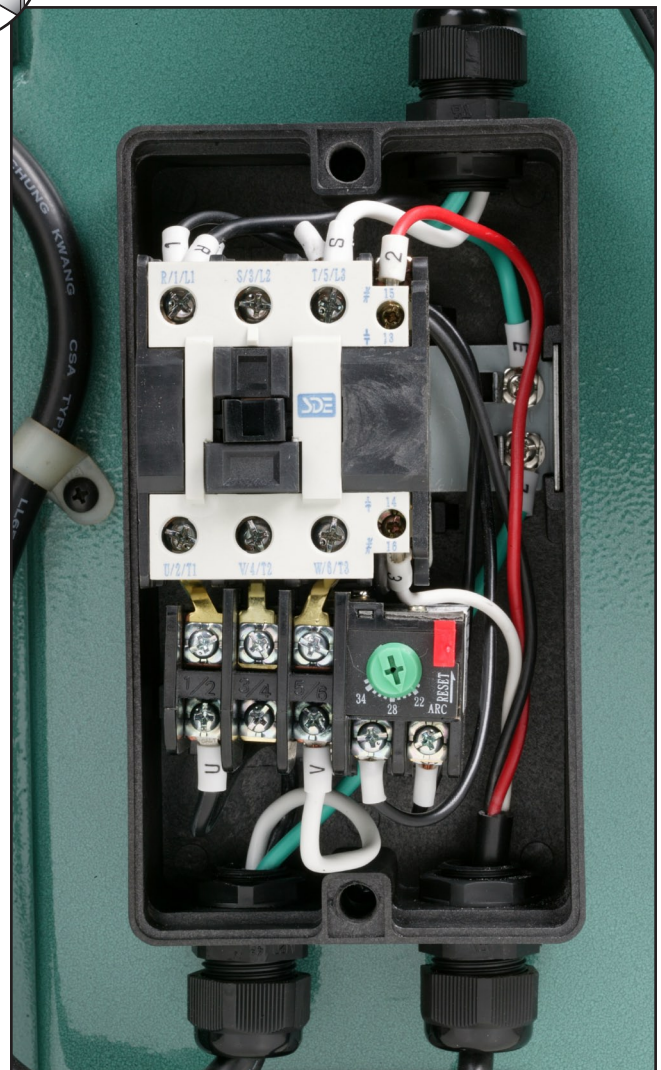


Figure 74. Magnetic switch.

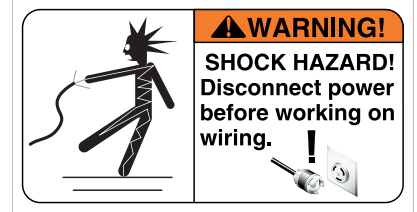




# Wiring Diagram

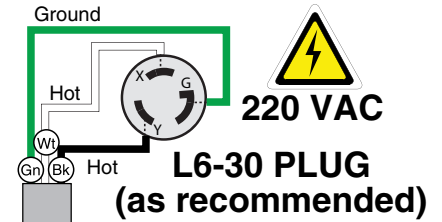
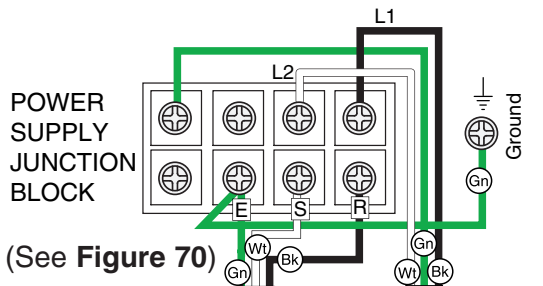


View this page in color at [www.grizzly.com](http://www.grizzly.com).

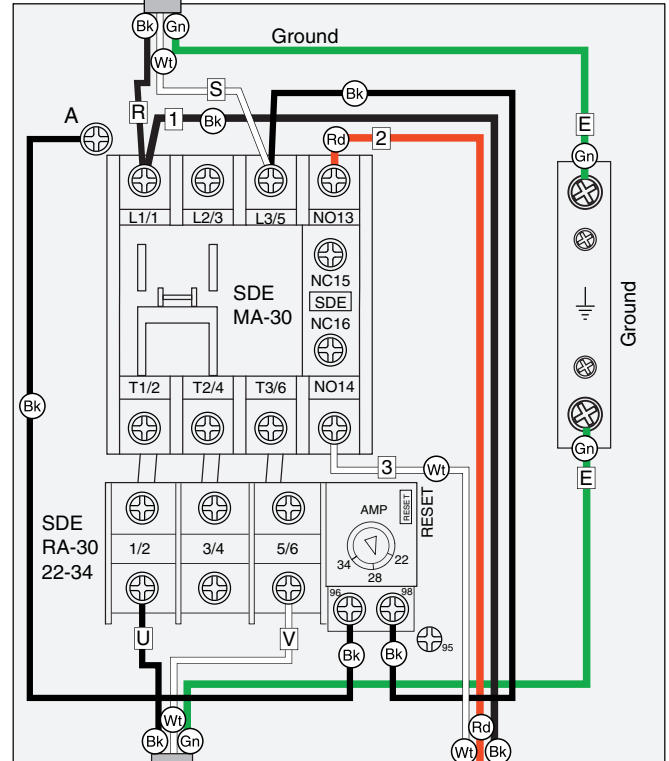


**COLOR KEY**

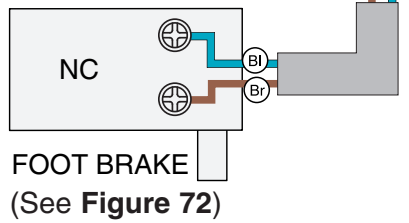
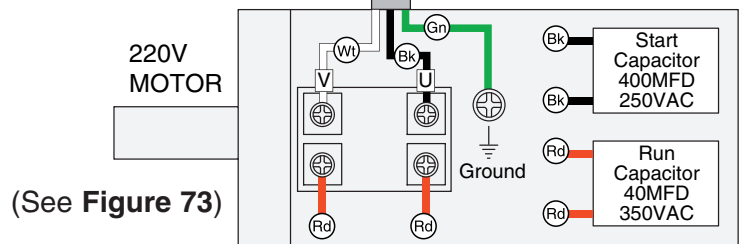
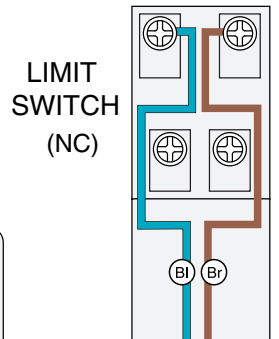
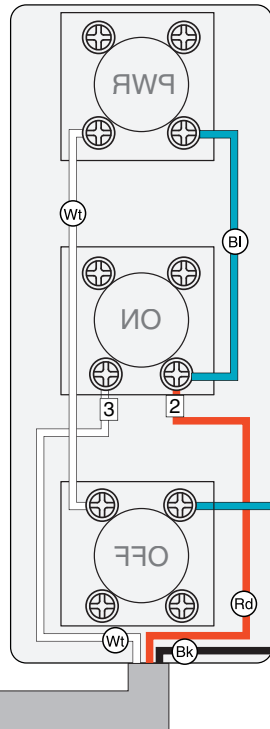
BLACK	
WHITE	
GREEN	
RED	
BLUE	
BROWN	



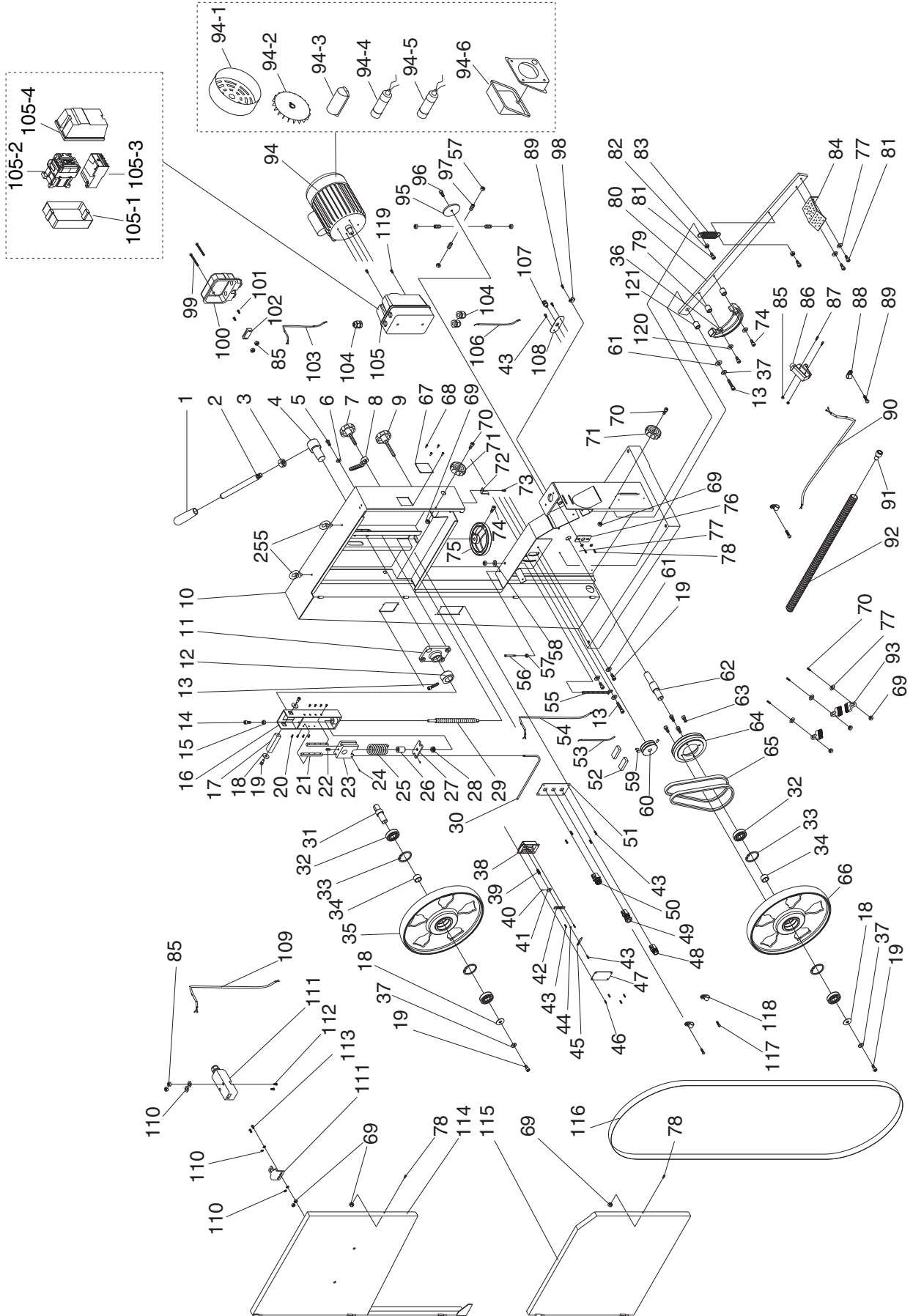
(See Figure 72)



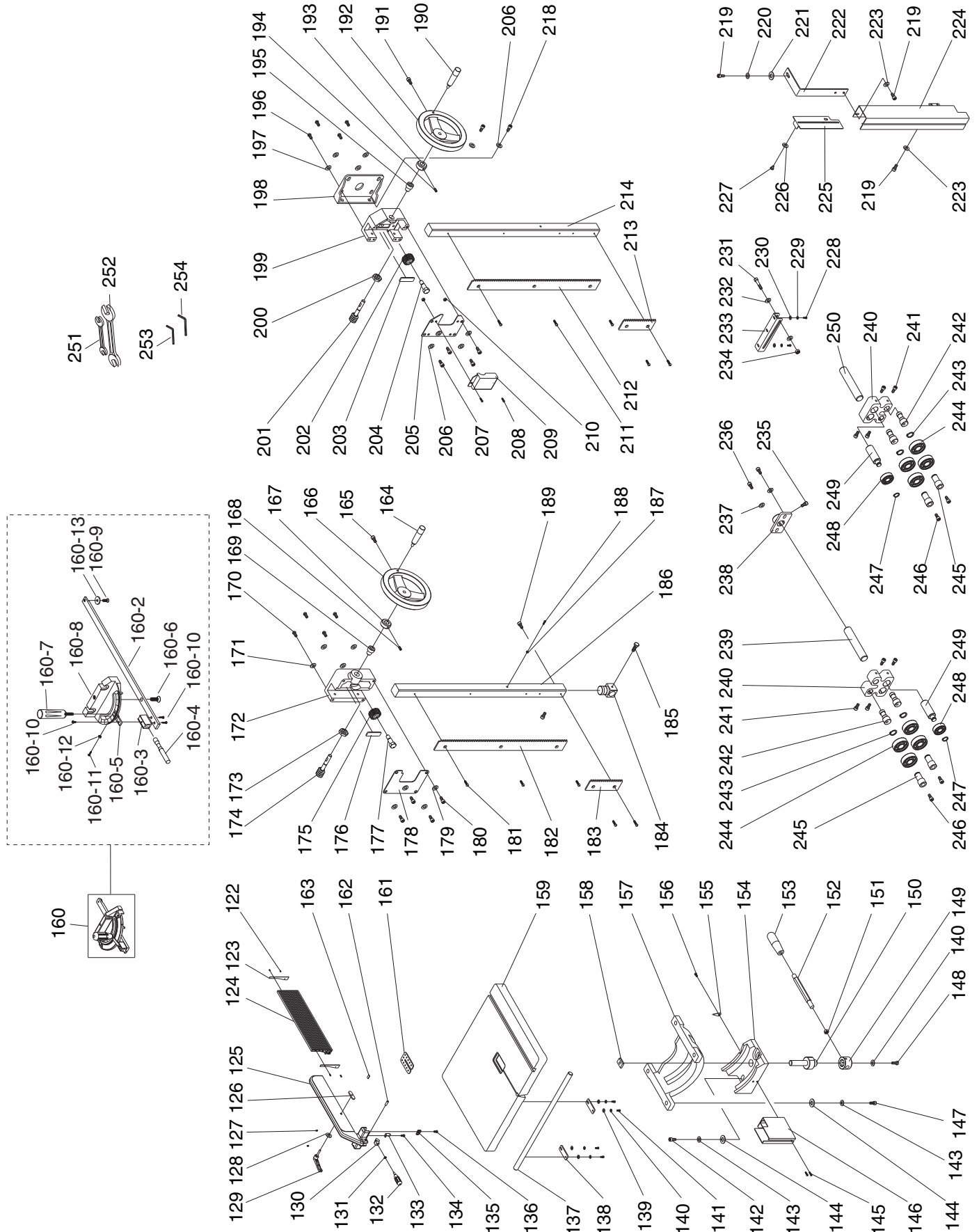
(See Figure 71)  
CONTROL PANEL  
(viewed from behind)



# Main Parts Breakdown



# Fence/Guides Parts Breakdown



# Parts List

REF	PART #	DESCRIPTION
1	P0636X001	HANDLE
2	P0636X002	LEVER ROD M16-2
3	PN13M	HEX NUT M16-2
4	P0636X004	ROTATE SHAFT
5	PSB25M	BUTTON HD CAP SCR M10-1.5 X 20
6	PLW06M	LOCK WASHER 10MM
7	P0636X007	BLADE TRACKING KNOB M10-1.5 x 25
8	P0636X008	BLADE TRACKING LOCK LEVER 10MM
9	P0636X009	GUIDE POST LOCK KNOB M10-1.5 X 25
10	P0636X010	MACHINE BODY
11	P0636X011	PILLOW BLOCK
12	P0636X012	CAM
13	PSB31M	CAP SCREW M8-1.25 X 25
14	PB82M	HEX BOLT M8-1.25 X 80
15	PN03M	HEX NUT M8-1.25
16	P0636X016	UPPER WHEEL HINGE
17	P0636X017	SQUARE SHAFT
18	P0636X018	SPECIAL WASHER 8MM
19	PSB14M	CAP SCREW M8-1.25 X 20
20	PFH39M	FLAT HD SCR M5-.8 X 16
21	P0636X021	LOCATE PLATE
22	PSS75M	SET SCREW M10-1.5 X 16
23	P0636X023	GUIDE BLOCK
24	PSS07M	SET SCREW M5-.8 X 5
25	P0636X025	COMPRESSION SPRING
26	P0636X026	BUSHING
27	P0636X027	PRESS BLOCK
28	P51201	THRUST BEARING 51201
29	P0636X029	BLADE TENSION SHAFT
30	P0636X030	TENSION LINE
31	P0636X031	UPPER WHEEL SHAFT
32	P6306ZZ	BALL BEARING 6306ZZ
33	PR64M	INT RETAINING RING 72MM
34	P0636X034	BUSHING
35	P0636X035	UPPER WHEEL
36	P0636X036	BRAKE PAD
37	PLW04M	LOCK WASHER 8MM
38	P0636X038	UPPER WHEEL SLIDING BRACKET
39	P0636X039	COMPRESSION SPRING
40	P0636X040	GUIDE PIN 3 X 12
41	P0636X041	MOVING PLATE
42	P0636X042	FIX PLATE
43	PHTEK15M	TAP SCREW M4 X 10
44	PW05M	FLAT WASHER 4MM
45	P0636X045	TENSION POINTER
46	P0636X046	TAP SCREW M4 X 15
47	P0636X047	TENSION SCALE
48	P0636X048	START SWITCH
49	P0636X049	STOP SWITCH
50	P0636X050	KEY SWITCH
51	P0636X051	SWITCH PLATE
52	P0636X052	CONNECTING CORD
53	P0636X053	CONNECTING CORD
54	P0636X054	SWITCH CORD

REF	PART #	DESCRIPTION
55	P0636X055	ADJUST BOLT
56	PB73M	HEX BOLT M10-1.5 X 50
57	PN02M	HEX NUT M10-1.5
58	PW04M	FLAT WASHER 10MM
59	PSS04M	SET SCREW M6-1 X 12
60	P0636X060	PULLEY
61	PW01M	FLAT WASHER 8MM
62	P0636X062	LOWER SHAFT
63	PSBS22M	BUTTON HD CAP SCR M8-1.25 X 20
64	P0636X064	PULLEY
65	PVA33	V-BELT A-33 4L330
66	P0636X066	LOWER WHEEL
67	P0636X067	TRANSLUCENT PIECE
68	P0636X068	RIVET 3.2 X 10
69	PLN03M	LOCK NUT M6-1
70	PS26M	PHLP HD SCR M6-1 X 20
71	P0636X071	KNOB
72	P0636X072	HEIGHT POINTER
73	PFS07M	FLANGE SCREW M5-.8 X 10
74	PSB02M	CAP SCREW M6-1 X 20
75	P0636X075	BLADE TENSION HANDLEWHEEL
76	P0636X076	LOWER WHEEL SUPPORT
77	PW03M	FLAT WASHER 6MM
78	PFS11M	FLANGE SCREW M6-1 X 10
79	P0636X079	BUSHING
80	P0636X080	BRAKE LEVER
81	PSB01M	CAP SCREW M6-1 X 16
82	PN01M	HEX NUT M6-1
83	P0636X083	EXTENSION SPRING
84	P0636X084	BRAKE STEP PLATE
85	PN04M	HEX NUT M4-.7
86	P0636X086	LIMIT SWITCH KL7141
87	PS51M	PHLP HD SCR M4-.7 X 30
88	P0636X088	CORD CLAMP 5/8"
89	PHTEK4M	TAP SCREW M4 X 8
90	P0636X090	BRAKE LEVER CORD
91	P0636X091	CORD BUSHING
92	P0636X092	PROTECT TUBE 1/2" X 43-5/16"
93	P0636X093	BRUSH
94	P0636X094	MOTOR 5HP
94-1	P0636X094-1	MOTOR COVER
94-2	P0636X094-2	MOTOR FAN
94-3	P0636X094-3	CAPACITOR COVER
94-4	P0636X094-4	START CAPACITOR 400MFD 250VAC
94-5	P0636X094-5	RUN CAPACITOR 40MFD 350VAC
94-6	P0636X094-6	JUNCTION BOX
95	P0636X095	ADJUSTMENT HUB COVER
96	PSBS22M	BUTTON HD CAP SCR M8-1.25 X 20
97	P0636X097	SET BOLT M10-1.5 X 30
98	P0636X098	CORD CLAMP 1/2"
99	PFS09M	FLANGE SCREW M5-.8 X 50
100	P0636X100	TERMINAL BOX
101	PS52M	PHLP HD SCR M4-.7 X 20
102	P0636X102	TERMINAL HOUSE



REF	PART #	DESCRIPTION
103	P0636X103	POWER CORD
104	P0636X104	STRAIN RELIEF M20
105	P0636X105	MAGNETIC SWITCH MPE-18
105-1	P0636X105-1	MAG SWITCH BACK COVER
105-2	P0636X105-2	CONTACTOR SDE MA-30
105-3	P0636X105-3	THERMAL RELAY SDE RA-30 22-34A
105-4	P0636X105-4	MAG SWITCH FRONT COVER
106	P0636X106	MOTOR CORD
107	P0636X107	STRAIN RELIEF M20
108	P0636X108	PLATE
109	P0636X109	SWITCH CORD
110	P0636X110	FLAT WASHER 4MM
111	P0636X111	DOOR LATCH SWITCH (ASM) ADZ-S11
112	PFS10M	FLANGE SCREW M4-.7 X 35
113	PS38M	PHLP HD SCR M4-.7 X 10
114	P0636X114	UPPER WHEEL COVER
115	P0636X115	LOWER WHEEL COVER
116	P0636X116	SAW BLADE 3TPI 162" X 1" X 0.035
117	PHTEK15M	TAP SCREW M4 X 10
118	P0636X118	CORD CLAMP 5/16"
119	PFS07M	FLANGE SCREW M5-.8 X 10
120	PLW03M	LOCK WASHER 6MM
121	P0636X121	BUSHING
122	P0636X122	TAP SCREW 3.5 X 8
123	P0636X123	FENCE PIECE 148 X 22 X 1
124	P0636X124	RESAW FENCE(AL) 505MM
125	P0636X125	FENCE
126	P0636X126	MOVING PLATE
127	P0636X127	SPECIAL PLASTIC SET SCREW
128	PW01M	FLAT WASHER 8MM
129	P0636X129	LOCK KNOB M8-1.25 X 44
130	P0636X130	PIVOT BLOCK
131	PN03M	HEX NUT M8-1.25
132	P0636X132	FENCE HANDLE M8-1.25 X 20
133	P0636X133	SPRING PIECE
134	P0636X134	FLANGE SCREW M4-.7 X 8
135	P0636X135	POINTER
136	PFS01M	FLANGE SCREW M5-.8 X 8
137	P0636X137	GUARD RAIL
138	P0636X138	GUARD RAIL PLATE
139	PW01M	FLAT WASHER 8MM
140	PLW04M	LOCK WASHER 8MM
141	PSB14M	CAP SCREW M8-1.25 X 20
142	PSB72M	CAP SCREW M10-1.5 X 30
143	PLW06M	LOCK WASHER 10MM
144	PW04M	FLAT WASHER 10MM
145	PFS11M	FLANGE SCREW M6-1 X 10
146	P0636X146	BLADE GUARD
147	PSB84M	CAP SCREW M10-1.5 X 35
148	PB09M	HEX BOLT M8-1.25 X 20
149	P0636X149	MICRO ADJUSTING RING
150	P0636X150	PRESS SHAFT

REF	PART #	DESCRIPTION
151	PN09M	HEX NUT M12-1.75
152	P0636X152	HANDLE SHAFT
153	P0636X153	HANDLE KNOB M12-1.75 (FEMALE)
154	P0636X154	TRUNNION HOUSING
155	P0636X155	POINTER
156	PS38M	PHLP HD SCR M4-.7 X 10
157	P0636X157	TRUNNION BLOCK
158	P0636X158	PRESS BLOCK
159	P0636X159	TABLE
160	P0636X160	MITER GAUGE ASSEMBLY
160-2	P0636X160-2	GUIDE BAR
160-3	P0636X160-3	LOCKING BRACKET
160-4	P0636X160-4	LOCKING SHAFT
160-5	P0636X160-5	POINTER
160-6	P0636X160-6	STEP SCREW
160-7	P0636X160-7	HANDLE 5/16-18 X 1-1/2
160-8	P0636X160-8	MITER GAUGE BODY
160-9	PFH9M	FLAT HD SCR M6-1 X 6
160-10	PS06	PHLP HD SCR 10-24 X 3/8
160-11	PS56M	PHLP HD SCR M4-.7 X 16
160-12	PN04M	HEX NUT M4-.7
160-13	PW01M	FLAT WASHER 8MM
161	P0636X161	TABLE INSERT
162	P0636X162	SHAFT
163	P0636X163	NYLON PIECE
164	P0636X164	HANDLE 3/8-16 X 1/2
165	PSB06M	CAP SCREW M6-1 X 25
166	P0636X166	HANDWHEEL
167	P0636X167	SWITCH BUSHING
168	PSS07M	SET SCREW M5-.8 X 5
169	P0636X169	BUSHING
170	PSBS04M	BUTTON HD CAP SCR M8-1.25 X 35
171	PW01M	FLAT WASHER 8MM
172	P0636X172	UPPER GUIDE BRACKET
173	PN05M	HEX NUT M16-1.5
174	P0636X174	WORM CYLINDER
175	P0636X175	WORM GEAR
176	P0636X176	FIXED PLATE
177	P0636X177	FIXED BOLT
178	P0636X178	COVER
179	PLW04M	LOCK WASHER 8MM
180	PSB11M	CAP SCREW M8-1.25 X 16
181	PFH19M	FLAT HD SCR M4-.7 X 10
182	P0636X182	RACK
183	P0636X183	EXTENSION RACK
184	P0636X184	UPPER GUIDE SUPPORT BLOCK
185	PB04M	HEX BOLT M6-1 X 10
186	P0636X186	UPPER GUIDE BAR
187	PN04M	HEX NUT M4-.7
188	PS38M	PHLP HD SCR M4-.7 X 10
189	PSB01M	CAP SCREW M6-1 X 16
190	P0636X190	HANDLE 3/8-16 X 1/2



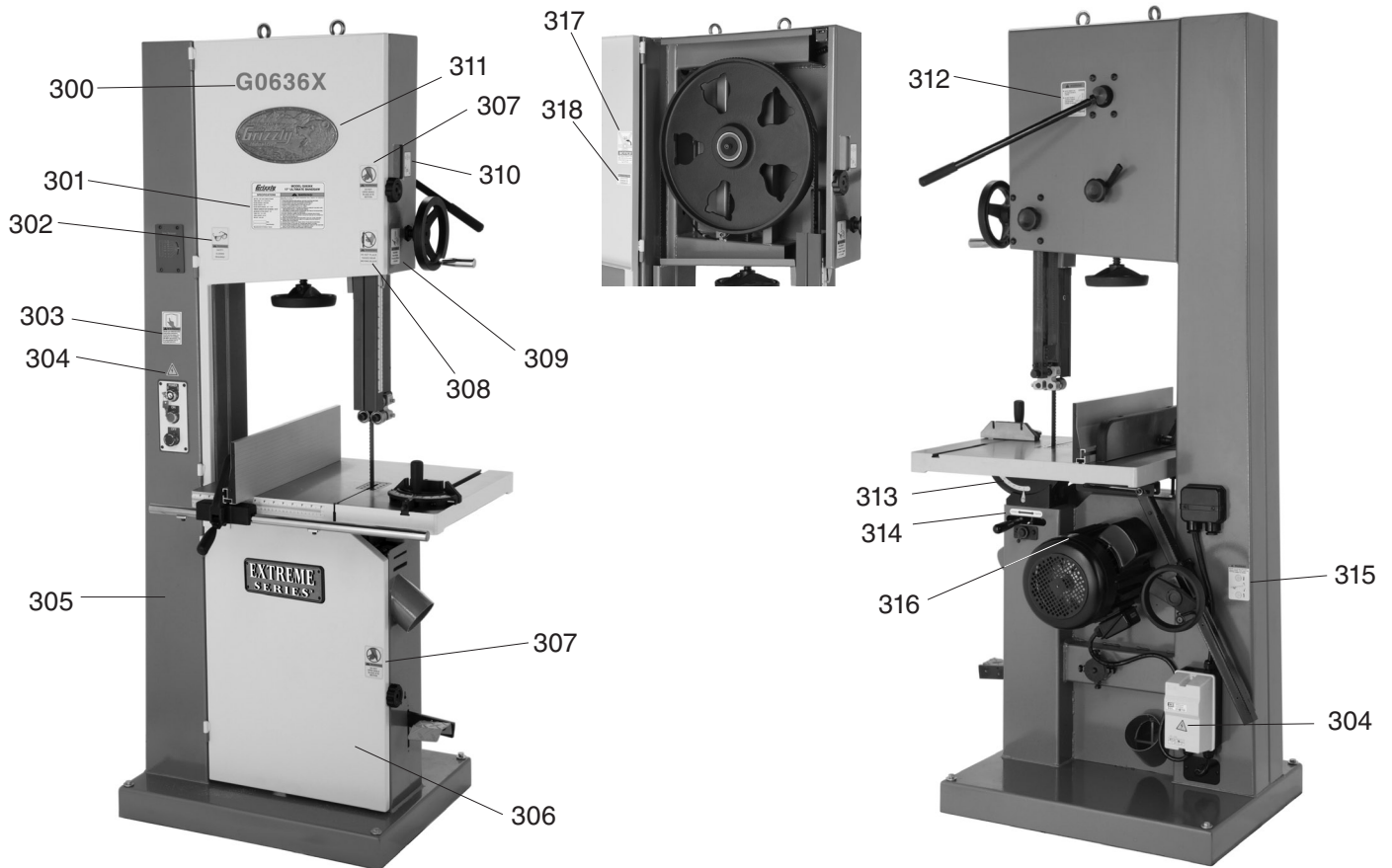


REF	PART #	DESCRIPTION
191	PSB06M	CAP SCREW M6-1 X 25
192	P0636X192	HANDWHEEL
193	P0636X193	SWITCH BUSHING
194	PSS07M	SET SCREW M5-.8 X 5
195	P0636X195	BUSHING
196	PSBS22M	BUTTON HD CAP SCR M8-1.25 X 20
197	PW01M	FLAT WASHER 8MM
198	P0636X198	SUPPORT PLATE
199	P0636X199	LOWER GUIDE BRACKET
200	PN05M	HEX NUT M16-1.5
201	P0636X201	WORM CYLINDER
202	P0636X202	WORM GEAR
203	P0636X203	FIXED PLATE
204	P0636X204	FIXED BOLT
205	P0636X205	COVER
206	PLW04M	LOCK WASHER 8MM
207	PSB11M	CAP SCREW M8-1.25 X 16
208	PFS07M	FLANGE SCREW M5-.8 X 10
209	P0636X209	COVER
210	PN06M	HEX NUT M5-.8
211	PFH19M	FLAT HD SCR M4-.7 X 10
212	P0636X212	RACK
213	P0636X213	EXTENSION RACK
214	P0636X214	SQUARE TUBE
218	PSB14M	CAP SCREW M8-1.25 X 20
219	PSB04M	CAP SCREW M6-1 X 10
220	PLW03M	LOCK WASHER 6MM
221	PW03M	FLAT WASHER 6MM
222	P0636X222	SUPPORT PLATE
223	PW03M	FLAT WASHER 6MM
224	P0636X224	PROTECT COVER (ASM)

REF	PART #	DESCRIPTION
225	P0636X225	SLIDING PLATE
226	P0636X226	FIBER WASHER 13MM
227	P0636X227	STEP SCREW
228	PSB04M	CAP SCREW M6-1 X 10
229	PLW03M	LOCK WASHER 6MM
230	PW03M	FLAT WASHER 6MM
231	PSB60M	CAP SCREW M8-1.25 X 55
232	PW01M	FLAT WASHER 8MM
233	P0636X233	SLIDING PLATE
234	PLN04M	LOCK NUT M8-1.25
235	PB83M	HEX BOLT M6-1 X 16
236	PSB01M	CAP SCREW M6-1 X 16
237	PW03M	FLAT WASHER 6MM
238	P0636X238	LOWER SUPPORT BRACKET
239	P0636X239	SHAFT
240	P0636X240	UPPER BLADE GUIDE SUPPORT
241	PB83M	HEX BOLT M6-1 X 16
242	P0636X242	BIAS SHAFT
243	PR05M	EXT RETAINING RING 15MM
244	P6202	BALL BEARING 6202ZZ
245	P0636X245	HANDLE BUSHING
246	PSB29M	CAP SCREW M6-1 X 40
247	PR03M	EXT RETAINING RING 12MM
248	P6201	BALL BEARING 6201ZZ
249	P0636X249	UPPER SPACING SLEEVE
250	P0636X250	SHAFT
251	PWR1013	WRENCH 10 X 13
252	PWR1719	WRENCH 17 X 19
253	PAW05M	HEX WRENCH 5MM
254	PAW06M	HEX WRENCH 6MM
255	P0636X255	EYE BOLT M10-1.5- X 15



# Labels/Cosmetic Parts



REF	PART #	DESCRIPTION
300	P0636X300	MODEL NUMBER LABEL
301	P0636X301	MACHINE ID LABEL
302	PLABEL-11	SAFETY GLASSES LABEL
303	PLABEL-12	READ MANUAL LABEL
304	PLABEL-14	ELECTRICITY LABEL
305	PPAINT-1	GRIZZLY GREEN PAINT
306	PPAINT-11	GREY PUTTY TOUCH UP PAINT
307	PLABEL-20	DONT OPEN LABEL 2"W X 3 5/16"H
308	PLABEL-19	HANDS/BS BLADE LABEL 2" X 3 5/16"H
309	PLABEL-18	UNPLUG BANDSAW LABEL 2" X 3 5/16"H

REF	PART #	DESCRIPTION
310	P0636X310	BLADE ASSEMBLY DIRECTION LABEL
311	G8589	GRIZZLY NAMEPLATE-LARGE
312	P0636X312	TENSION ADJ LABEL
313	P0636X313	TABLE ANGLE SCALE
314	P0636X314	TABLE LOCK LEVER LABEL
315	P0636X315	TABLE TILT HANDWHEEL WARNING LABEL
316	P0636X316	MOTOR LABEL
317	P0636X317	UPPER WHEEL HINGE/STOP BOLT LABEL
318	P0636X318	PATENT LABEL

## WARNING

Safety labels warn about machine hazards and ways to prevent injury. The owner of this machine **MUST** maintain the original location and readability of the labels on the machine. If any label is removed or becomes unreadable, **REPLACE** that label before using the machine again. Contact Grizzly at (800) 523-4777 or [www.grizzly.com](http://www.grizzly.com) to order new labels.



# WARRANTY AND RETURNS

---

Grizzly Industrial, Inc. warrants every product it sells for a period of **1 year** to the original purchaser from the date of purchase. This warranty does not apply to defects due directly or indirectly to misuse, abuse, negligence, accidents, repairs or alterations or lack of maintenance. This is Grizzly's sole written warranty and any and all warranties that may be implied by law, including any merchantability or fitness, for any particular purpose, are hereby limited to the duration of this written warranty. We do not warrant or represent that the merchandise complies with the provisions of any law or acts unless the manufacturer so warrants. In no event shall Grizzly's liability under this warranty exceed the purchase price paid for the product and any legal actions brought against Grizzly shall be tried in the State of Washington, County of Whatcom.

We shall in no event be liable for death, injuries to persons or property or for incidental, contingent, special, or consequential damages arising from the use of our products.

To take advantage of this warranty, contact us by mail or phone and give us all the details. We will then issue you a "Return Number," which must be clearly posted on the outside as well as the inside of the carton. We will not accept any item back without this number. Proof of purchase must accompany the merchandise.

The manufacturers reserve the right to change specifications at any time because they constantly strive to achieve better quality equipment. We make every effort to ensure that our products meet high quality and durability standards and we hope you never need to use this warranty.

Please feel free to write or call us if you have any questions about the machine or the manual.

Thank you again for your business and continued support. We hope to serve you again soon.







# WARRANTY CARD

Name \_\_\_\_\_  
 Street \_\_\_\_\_  
 City \_\_\_\_\_ State \_\_\_\_\_ Zip \_\_\_\_\_  
 Phone # \_\_\_\_\_ Email \_\_\_\_\_ Invoice # \_\_\_\_\_  
 Model # \_\_\_\_\_ Order # \_\_\_\_\_ Serial # \_\_\_\_\_

The following information is given on a voluntary basis. It will be used for marketing purposes to help us develop better products and services. **Of course, all information is strictly confidential.**

1. How did you learn about us?

Advertisement                       Friend                       Catalog  
 Card Deck                               Website                       Other:

2. Which of the following magazines do you subscribe to?

<input type="checkbox"/> Cabinet Maker	<input type="checkbox"/> Popular Mechanics	<input type="checkbox"/> Today's Homeowner
<input type="checkbox"/> Family Handyman	<input type="checkbox"/> Popular Science	<input type="checkbox"/> Wood
<input type="checkbox"/> Hand Loader	<input type="checkbox"/> Popular Woodworking	<input type="checkbox"/> Wooden Boat
<input type="checkbox"/> Handy	<input type="checkbox"/> Practical Homeowner	<input type="checkbox"/> Woodshop News
<input type="checkbox"/> Home Shop Machinist	<input type="checkbox"/> Precision Shooter	<input type="checkbox"/> Woodsmith
<input type="checkbox"/> Journal of Light Cont.	<input type="checkbox"/> Projects in Metal	<input type="checkbox"/> Woodwork
<input type="checkbox"/> Live Steam	<input type="checkbox"/> RC Modeler	<input type="checkbox"/> Woodworker West
<input type="checkbox"/> Model Airplane News	<input type="checkbox"/> Rifle	<input type="checkbox"/> Woodworker's Journal
<input type="checkbox"/> Modeltec	<input type="checkbox"/> Shop Notes	<input type="checkbox"/> Other:
<input type="checkbox"/> Old House Journal	<input type="checkbox"/> Shotgun News	

3. What is your annual household income?

\$20,000-\$29,000                       \$30,000-\$39,000                       \$40,000-\$49,000  
 \$50,000-\$59,000                       \$60,000-\$69,000                       \$70,000+

4. What is your age group?

20-29                                       30-39                                       40-49  
 50-59                                       60-69                                       70+

5. How long have you been a woodworker/metalworker?

0-2 Years                       2-8 Years                       8-20 Years                       20+ Years

6. How many of your machines or tools are Grizzly?

0-2                       3-5                       6-9                       10+

7. Do you think your machine represents a good value?

Yes                       No

8. Would you recommend Grizzly Industrial to a friend?

Yes                       No

9. Would you allow us to use your name as a reference for Grizzly customers in your area?

**Note:** We never use names more than 3 times.

Yes                       No

10. Comments: \_\_\_\_\_

\_\_\_\_\_  
 \_\_\_\_\_  
 \_\_\_\_\_

CUT ALONG DOTTED LINE



FOLD ALONG DOTTED LINE

\_\_\_\_\_  
\_\_\_\_\_  
\_\_\_\_\_



Place  
Stamp  
Here



**GRIZZLY INDUSTRIAL, INC.**  
P.O. BOX 2069  
BELLINGHAM, WA 98227-2069



FOLD ALONG DOTTED LINE

Send a Grizzly Catalog to a friend:

Name \_\_\_\_\_  
Street \_\_\_\_\_  
City \_\_\_\_\_ State \_\_\_\_\_ Zip \_\_\_\_\_

TAPE ALONG EDGES--PLEASE DO NOT STAPLE



# *grizzly.com*

**TOOL WEBSITE**

Buy Direct and Save with Grizzly® – Trusted, Proven and a Great Value!

*Visit Our Website Today And Discover  
Why Grizzly® Is The Industry Leader!*

- SECURE ORDERING
- ORDERS SHIPPED WITHIN 24 HOURS
- E-MAIL RESPONSE WITHIN ONE HOUR

-OR-

Call Today For A **FREE**  
Full Color Catalog

**1-800-523-4777**

